A527-42-880
Issue B
October 1991

Compact Drystar Pumps

Models

CDP40i and CDP80i

Installation and Operation Manual

 **EDWARDS**

Edwards High Vacuum International
Manor Royal, Crawley, West Sussex, RH10 2LW, UK
Telephone: (01293) 528844 Fax: (01293) 533453 Telex: 87123 Edivac G



Relubricate the rotor bearings

1 Introduction

The instruction manual specifies that you should relubricate the pump rotor bearings every 6 months, however you only need to relubricate the bearings every year. The following changes in this amendment reflect this.

2 Procedure

The first sentence of Section 5.5.3 of the instruction manual (Rotor Bearing Re-lubrication) is now incorrect and should read as follows:

"The rotor bearings (see Figure 17) should be cleaned, inspected and repacked with grease every 12 months."

3 Maintenance Schedule

In Section 5.7, amend the maintenance schedule on page 46 of the instruction manual so that the maintenance interval for the "Re-lubricate rotor bearing" operation is 12 monthly (not 6 Monthly).

A527-42-880

Issue B

Amendment 2

Pump coolant

The pump coolant referenced in the instruction manual is no longer available. Change all references to Fernox coolant (Item Number H128-01-001) in the instruction manual to refer to Drystar coolant (Item Number H128-10-003).

Voltage variants

The CDP pump is suitable for use with a 380 V, 60 Hz electrical supply; make the following changes to include information for this voltage variant of the pump:

- Replace the table in Section 2.4 (Full Load Current Ratings) with the following new table:

Supply Voltage/ → Frequency	200 V 50/60 Hz	208 V 60 Hz	220 V 50 Hz	230 V 60 Hz	240 V 50 Hz	380 V 50 Hz	380 V 60 Hz	415 V 50 Hz	460 V 60 Hz
Model ↓	Full Load Current (A)								
CDP40i	9.2	8.8	8.4	8.0	7.7	4.9	5.3	4.5	4.0
CDP80i	16.0	15.4	14.5	13.9	13.4	8.4	9.2	7.7	7.0

- Replace the information in Section 2.5 (Ordering Codes) with the following new information:

	CDP40i	CDP80i
Number of phases	3	3
Supply Voltage		
220-240 V/380-415 V, 50 Hz	A527-41-935	A527-81-935
208-230 V/460 V, 60 Hz	A527-41-995	A527-81-995
200 V, 50 Hz/200-208 V, 60 Hz/380 V, 60 Hz	A527-41-934	A527-81-934

About this Manual

Purpose of this Manual

This manual has been written to provide all relevant information for installing, operating and maintaining your vacuum equipment. It contains essential safety information which supplements the safety features of the equipment.

We recommend that you read these instructions before attempting to instal or operate your equipment. This will ensure the maximum service life of the product and of your system.

Safety Information

Throughout this manual a policy of highlighting special safety information and precautions has been adopted in the form of WARNING and CAUTION notes, which must be observed during installation, operation and servicing of the equipment. The use of WARNINGS and CAUTIONS is defined below.

WARNING

Warnings are given where failure to observe the instruction could result in injury or death to personnel.

CAUTION

Cautions are given where failure to observe the instructions could result in damage to the product, associated equipment and or process.

Edward's Support Publications

Where appropriate, manuals for major components used within the product are included as supplements to this manual. These are detailed on the front cover or at the end of the contents list.

Edwards also have a number of support publications available which include health and safety data sheets and guidance notes on good vacuum practice.

Customer Care

Edwards' Capability

Thank you for choosing Edwards High Vacuum International as your vacuum equipment supplier. We have been supplying vacuum equipment for over 50 years and have won a number of Queen's Awards for our innovative work in vacuum technology.

Edwards offer a full range of vacuum products including:

- rotary vacuum pumps (wet and dry)
- mechanical booster pumps
- high vacuum pumps (turbomolecular, cryogenic and vapour diffusion)
- vacuum instruments and gauge heads
- associated hardware (flanges, couplings, 'O' rings etc.)

Your equipment incorporates a number of advanced features developed from our many years of experience attained in the vacuum industry. It has been manufactured to the highest standards and then fully tested to ensure that it will operate safely and reliably.

Customer Support Services

All Edwards products are supplied and supported by an extensive network of dealers and service centres who can be contacted for information on any of the following:

applications information and advice
equipment service repair
spare parts and maintenance kits
maintenance contracts

A list of Edwards service centres is attached to the rear of this manual.

Communication with your Supplier

You should contact the supplier you purchased your equipment from in the event that you have any enquiry or concern about

- customer support services
- warranty claims
- damage in transit

You should have the following information to hand:

- model, code number and serial number (if any) of your equipment
date of purchase
- your order number and your suppliers' invoice number

Your attention is drawn to the Health and Safety Forms HS1 and HS2 attached to the rear of this manual. In the event that your equipment is to be returned to your supplier or to Edwards, Form HS2 must be completed.

Contents

Section	Title	Page
1	INTRODUCTION	1
1.1	Scope of Manual	1
1.2	Applications	1
1.3	General Description	1
1.3.1	Construction	1
1.3.2	Gas System	3
1.3.3	Cooling System	3
1.3.4	Electrical System	3
1.4	Exhaust System	5
1.4.1	General Description	5
1.4.2	Exhaust Silencer	5
1.4.3	Exhaust Check Valve	6
1.5	Optional Extras	6
1.5.1	Ei Controller	6
1.5.2	Flap Valve	7
1.5.3	Booster Pump Fitting Kits	7
1.5.4	CDPi Nitrogen Purge Kit	7
2	TECHNICAL DATA	8
2.1	General	8
2.2	Performance Data	8
2.3	Services	13
2.4	Full Load Current Ratings	13
2.5	Ordering Codes	14
2.6	Cooling System	14
2.7	Lubrication System	14
2.7.1	Gear Box	14
2.7.2	Roller Bearings	14
3	INSTALLATION AND COMMISSIONING	15
3.1	Safety	15
3.2	System Design Considerations	15
3.3	Unpacking	19
3.4	Component Identification	19
3.5	Pre-installation Checks	20
3.6	Removing the Enclosure	20
3.7	Filling the Pump with Coolant	22
3.8	Installing Optional Extras	24
3.9	Filling the Pump with Oil	24
3.10	Siting the Pump	25
3.11	Installing the Exhaust Silencer	26
3.12	Installing the Exhaust Check Valve	28
3.13	Fitting a Booster Pump	29

Section	Title	Page
3.14	Connecting the Cooling Water Supply	30
3.15	Electrical Supply Connection	32
3.15.1	Connecting to a Contactor	32
3.15.2	Connecting the Ei Controller to the Electrical Supply	32
3.15.3	Connecting the Thermal Snap Switch	32
3.15.4	Checking Pump Rotation	33
3.16	Leak Testing the Pump and its Accessories	33
3.17	Connecting the Nitrogen Supply	34
3.18	Connecting to the Process System	35
3.19	Leak Testing the Installation	36
3.20	Replacing the Enclosure	36
4	OPERATION	37
4.1	Introduction	37
4.2	Start-up Procedure	37
4.2.1	Pre-start Checks	37
4.2.2	Start-up and Water Temperature Control Valve Setting	38
4.2.3	Operational Checks	39
4.2.4	Pumping Condensable Vapours	39
4.3	Pump Shut-down	40
5	MAINTENANCE	41
5.1	Introduction	41
5.2	Safety	41
5.3	Monthly Routine Maintenance	42
5.4	Three Monthly Routine Maintenance	42
5.5	Six Monthly Routine Maintenance	43
5.5.1	General	43
5.5.2	Gearbox Oil Change	43
5.5.3	Rotor Bearing Re-lubrication	43
5.6	Testing the Installation	45
5.7	Maintenance Schedule	45
5.8	Overhaul	46
6	SPARES AND ACCESSORIES	47
6.1	Introduction	47
6.2	How to Order Spares	47
6.3	List of Accessories	47

Section	Title	
7	HEALTH AND SAFETY ASPECTS - LUBRICANTS	49
7.1	Inhalation	49
7.2	Fire Hazards/Storage and Spillage	49
	HEALTH AND SAFETY FORM	

List of Illustrations

Figure No.	Title	
1	The CDP Pump	2
2	Gas System	4
3	CDP40i - Dimension Details	9
4	CDP80i - Dimension Details	10
5	CDP40i Performance	11
6	CDP80i Performance	12
7	Mounting the Exhaust Line Accessories	17
8	Removing the Enclosure	21
9	Cooling System	23
10	Oil Filler Plug and Sight Glass Location	25
11	Pump Exhaust Accessories	26
12	Clamp Orientation	27
13	Fitting the EH250 Booster Pump	30
14	Cooling Water Connections	31
15	Nitrogen Pipe Connector Components	34
16	Temperature Measurement Point	40
17	Rotor Bearing Re-lubrication	44

List of Supplementary Instructions

A440-03-880 CDP Accessories - Exhaust Check Valve
A386-11-880 CDP Accessories - Exhaust Silencer

List of Associated Publications

A504-80-880 Fitting and Manifold Kits for EH250/EH500A to CDP40/80
A504-51-880 CDP Accessories - exhaust flap valve
A380-41-880 CDP Accessories - Ei Controller
A504-45-880 CDP Accessories - CDPi Nitrogen Purge Kits
12-A526-60-895 CDP - Use with dry scrubbers
P500-10-000 Leak testing CDP installations
A100-00-880 Guidelines for eliminating the risk of explosion when pumping hazardous substances with primary vacuum pumps

1 INTRODUCTION

1.1 Scope of Manual

This manual provides installation, operation and maintenance instructions for the following Edwards High Vacuum International products:

Compact Drystar Pump CDP40i - Part No A527-42-000

Compact Drystar Pump CDP80i - Part No A527-82-000

Full details are provided to enable the pumps to be used efficiently and special attention has been given to the aspects of safety, further details of which are contained in the section entitled SAFETY PRECAUTIONS at the front of this manual. Instructions are also provided for fitting accessories supplied with the pumps, together with recommendations for system configurations.

1.2 Applications

Edwards CDP i pumps have been designed to provide a safe, reliable, simple-to-operate pumping package. They are designed to operate at pressures between atmospheric and ultimate vacuum without any lubricating or sealing fluid within the pumping chamber. This ensures a clean pumping system without back-migration of oil particles into the system being evacuated.

The pumps are most suitable for light processes which primarily require the cleanliness of vacuum offered by dry pumps (e.g. clean sputtering, loadlock, etc.). Further details on pump applications and product compatibilities can be obtained from Edwards High Vacuum International.

1.3 General Description

1.3.1 Construction

Both the CDP40i and CDP80i are four stage, positive displacement rotary pumps in which pairs of intermeshing rotors (of different profiles mounted on common shafts) are held in correct phase relation by a pair of timing gears. The timing gears are made from EN24 alloy steel and, together with the adjacent double-row angular contact ball bearings, are oil lubricated. A sight-glass is fitted to the gear casing to enable the lubricant level to be checked visually.

Pump shafts and rotors are made from spheroidal graphite cast iron and internal and external shaft seals on the motor drive shaft are made of Polytetrafluoroethylene (PTFE). Roller bearings are located on the non-motor end of the shaft, near to the pump inlet. These bearings are packed with PFPE (Perfluoropolyether) grease.

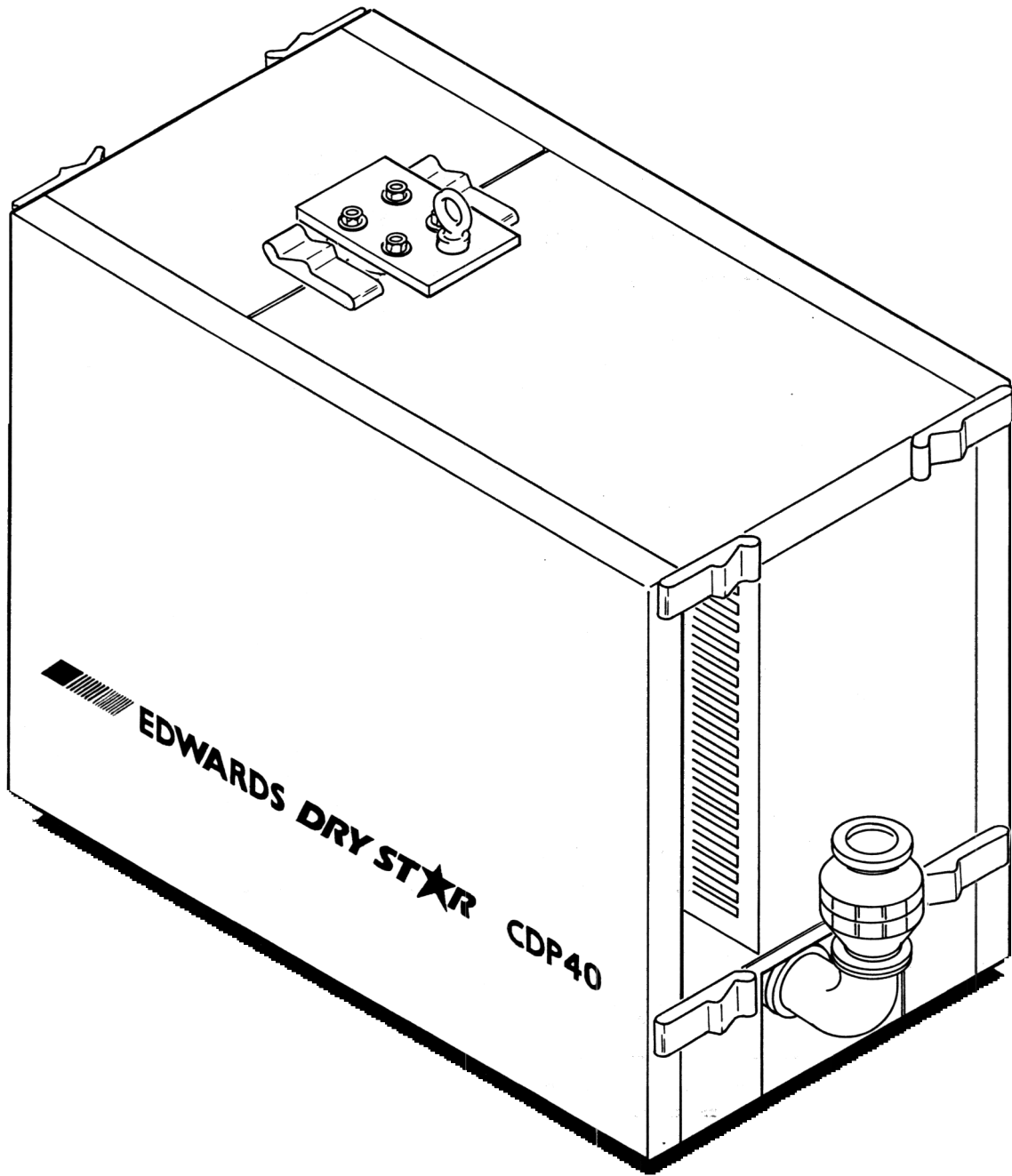

Figure The CDP Pump

The pump is contained within an enclosure (See Figure 1) and is fixed to the base via anti-vibration mountings. The enclosure is manufactured from steel and is provided with casters and levelling feet. Both of the side panels and the top panel can be removed from the base to provide unrestricted access to the pump components for installation and maintenance purposes.

Gas System

The CDP i pumps employ a gas system, as shown in Figure 2, which delivers nitrogen to the gas packed shaft seals. Injecting nitrogen into the shaft seals enables them to be held at a positive pressure during pump operation, thus preventing corrosive and toxic product gases from entering the gearbox, preventing gearbox oil from entering the pump and also preventing debris from reaching the shaft seals. A non-return valve is fitted in the shaft seal vent line, where it joins the outlet connector.

A bulkhead connector on the pump services panel is provided to enable a nitrogen gas supply (at a pressure of 8 psi) to be connected. Distribution to the various gas inlets around the pump is via stainless steel pipes.

Cooling System

An indirect water cooling system is employed to cool the LV stage of the pump (all other stages are air cooled). The cooling water supply and return are connected to the pump bulkhead quick release couplings mounted on the pump services panel. Cooling water is circulated through copper coils to extract heat from the coolant in circulation around the pump body.

The coolant (or secondary circuit) is circulated around the pump body by natural convection. Cooling water in the primary circuit is controlled by a thermostatic valve to maintain the pump at a constant operating temperature.

Coolant is added to the system via the header tank located on top of the pump. Using an indirect cooling system prevents corrosion of the pump body and reduces the effects of impurities in the cooling water supply.

Electrical System

The electrical system of the CDP i pumps provides power to drive the pump motor and also provides connections to a thermal snap switch mounted on the pump body. The power for driving the motor is supplied via a 5 metre length of 2.5 mm², 4-core cable which enters the pump via a gland in the pump services bulkhead. The pump should be connected to the electrical supply via a suitably rated starter/isolator.

- 1. Gearbox Vent
- 2. Shaft Seal Supply
- 3. Services Panel
- 4. Nitrogen Inlet Connection
- 5. Non-return Valve
- 6. Shaft Seal Purge

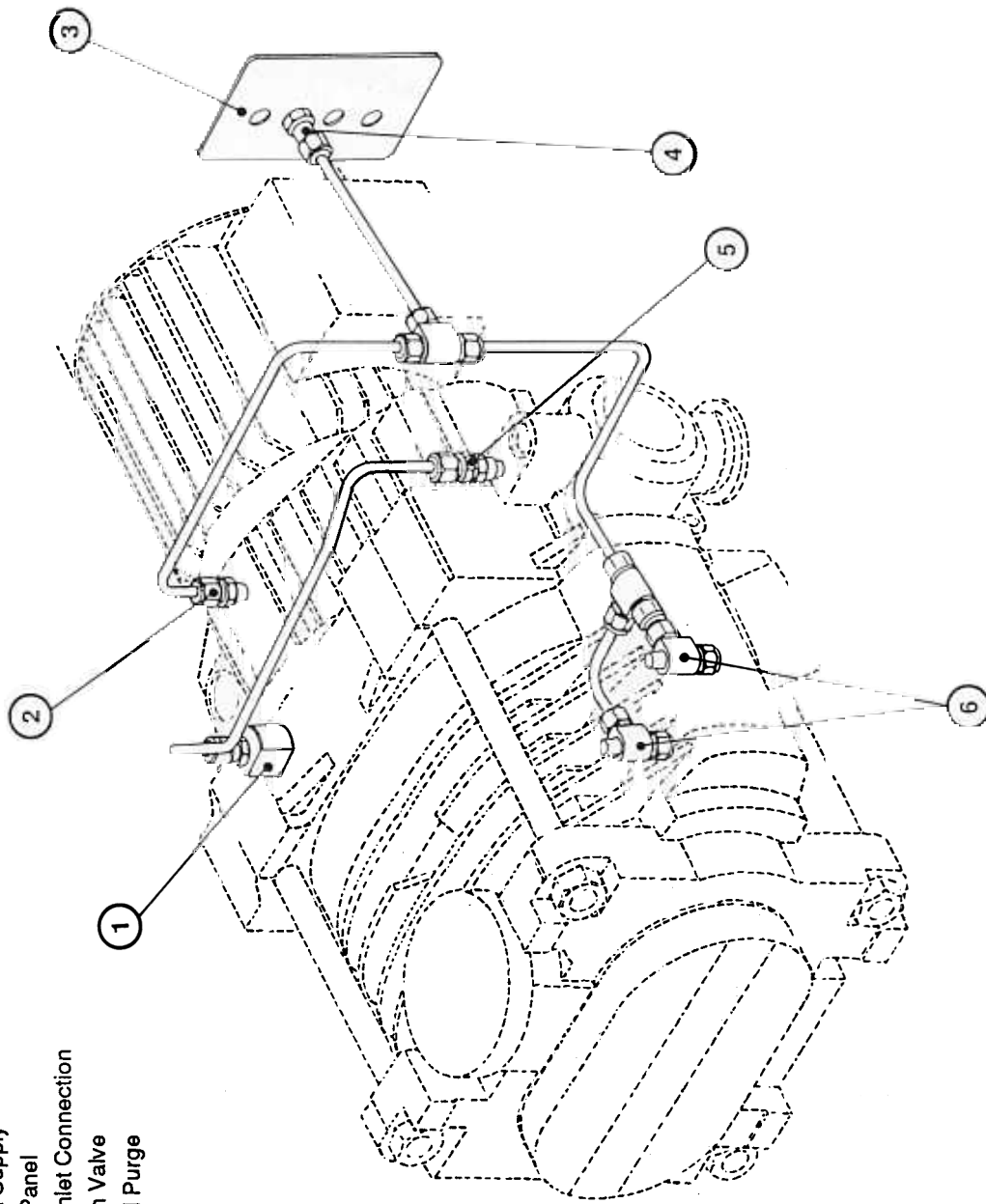

Figure 2 - Gas System

The connection to the thermal snap switch is made via a 5 metre length of 0.75 mm², 3-core cable which enters the pump via a separate gland in the pump services bulkhead. This switch can be arranged either to switch off the electrical supply to the pump motor or to initiate a warning in the event of the pump overheating.

Both cables are fitted with clips to provide strain relief as they pass through the services panel.

The pump has been designed for use with the Ei Controller, details of which are contained in Section 1.5.

Exhaust System

1.4.1 General Description

Because of the toxic and aggressive nature of the gases that the CDP i pumps are designed to handle, the pump silencer and check valve must be properly connected to the house exhaust system as detailed in Section 3 - INSTALLATION. This system must be designed to handle and dispose of the process gases in a safe manner.

The pump is fitted with a cast iron elbow outlet connector. The elbow contains a port which allows gearbox vent gases to join the main exhaust gas stream.

Exhaust Silencer

The exhaust silencer is designed to produce the maximum attenuation of the exhaust gas pressure pulsations, in order to eliminate pump induced resonance within the house exhaust system. It is suitable for use on all of the corrosive and particulate gases typically found in the semiconductor industry. The reduction of exhaust system vibration is essential to reduce the effects of noise and dust generation.

Because of the nature of the products handled by CDP systems, the silencer is subjected to stringent leak testing during manufacture, to ensure safety in use. Cleaning is designed to be simple, with the minimum of disturbance of sealing surfaces, thus reducing the possibility of leaks after maintenance.

Full details of the construction, function, installation and maintenance of the silencer are contained in the supplementary instructions supplied in the exhaust silencer pack - see CDP Accessories - Exhaust Silencer, Publication No. A386-11-880.

Exhaust Check Valve

In common with the exhaust silencer, the check valve is suitable for use on all of the corrosive and particulate gases typically found in the semiconductor industry. It is designed to prevent the rapid suck-back of exhaust duct vapours after pump shut-down, before back filling of the pump with nitrogen purge gas. It also provides additional attenuation of the exhaust gas pressure pulsations.

Full details of the construction, function, installation and maintenance of the check valve are contained in the supplementary instructions supplied in the check valve pack - see CDP Accessories - Exhaust Check Valve, Publication No. A440-03-880.

1.5 Optional Extras

The optional extras available for the CDP40 i and CDP80 i pumps are outlined in the following Sections; ordering codes for these items are listed in section 6.3

Ei Controller

The Ei controller is available as an optional extra and is capable of controlling the CDP i pump either as a stand-alone pump or in combination with a mechanical booster pump (EH250 or EH500A). The controller is pushbutton operated and provides sequenced start and shut down of the pumps. It also incorporates an interlock to prevent the operation of the booster pump with the CDP switched off.

Lamps are provided to indicate the following functions:

Power on

CDP on

Booster on

Warning lamps are provided to indicate operation of the thermal snap switch, CDP shut-down and booster pump shut-down caused by excessive current consumption. Switched and unswitched 24V outputs are also provided to enable suitable interlock functions to be easily incorporated.

Full details of the construction, function, installation and maintenance of the Ei controller are contained in the supplementary instructions supplied in the Ei controller pack - see CDP Accessories - Ei Controller, Publication No. A380-41-880.

Flap Valve

A flap valve is available as an optional extra and has a similar function to the exhaust check valve (see Section 1.4.3) in that it prevents rapid suck-back of exhaust duct vapours after pump shut-down; it also, however, prevents back-migration during operation, improving pump performance when used on clean systems that are not subjected to particulate deposits.

Full details of the construction, function, installation and maintenance of the flap valve are contained in the working instructions supplied with the accessory - see CDP Accessories - Flap Valve, Publication No. A504-51-880.

Booster Pump Fitting Kits

Fitting kits are available for connecting an Edwards EH250 or EH500A booster pump to the inlet flange of the CDP. Each kit contains a spacer flange and all of the fixings and seals required to secure the pumps together.

Full details on the fitting procedure are contained in the working instructions supplied with each kit (see the List of Associated Publications on page iv of the contents list). Connection of the EH250 booster to the CDP40 i does not require a special fitting kit and the procedure for fitting this combination is detailed in Section 3.13

CDPi Nitrogen Purge Kit

This kit is available so that nitrogen can be fed to provide 2nd/3rd stage, gas ballast boost and inlet purge.

Full details of the construction, function, installation and maintenance of the 2nd/3rd stage, gas ballast boost and inlet purge connection kit are contained in the working instructions supplied with the accessory - see CDP Accessories - CDPi Nitrogen Purge Kit, Publication No. A504-45-880.

2 TECHNICAL DATA

2.1 General

	CDP40 i	CDP80 i
Overall Dimensions	See Figure 3	See Figure 4
Weight	187 kg	225 kg
Motor Rating	2.2 kW	4 kW
Warm-up Time	15 mins	15 mins
Thermal Snap Switch Opening Temperature	71°C	71°C
Vacuum Connections		
Inlet	ISO40	ISO63
Outlet	NW40	NW40
Vacuum System		
Maximum Leak Rate	1×10^{-5} mbar.l.s ⁻¹	1×10^{-5} mbar.l.s ⁻¹
Exhaust System		
Maximum Leak Rate	1×10^{-5} mbar.l.s ⁻¹	1×10^{-5} mbar.l.s ⁻¹
Operating Temperature	+5 to +40°C	+5 to +40°C
Operating Humidity	90% RH	90% RH

2.2 Performance Data

	CDP40 i	CDP80 i
Pumping Speed Range	See Figure 5	See Figure 6
Peak Pumping Speed		
50 Hz	44 m ³ h ⁻¹	80 m ³ h ⁻¹
60 Hz	55 m ³ h ⁻¹	96 m ³ h ⁻¹
Displacement (Swept Volume)		
50 Hz	52 m ³ h ⁻¹	91.5 m ³ h ⁻¹
60 Hz	62.4 m ³ h ⁻¹	109.8 m ³ h ⁻¹
Ultimate Vacuum without Gas Ballast		
50 Hz	5×10^{-2} mbar	3×10^{-2} mbar
60 Hz	3×10^{-2} mbar	3×10^{-2} mbar
Ultimate Vacuum with full Gas Ballast		
50 Hz	5×10^{-2} mbar	3×10^{-2} mbar
60 Hz	3×10^{-2} mbar	3×10^{-2} mbar

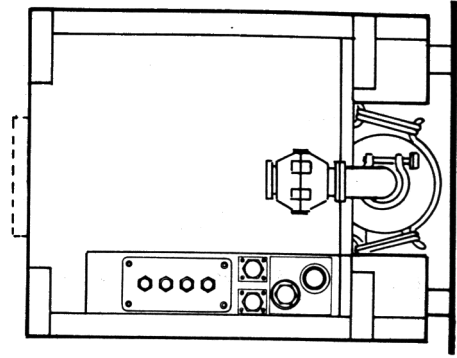
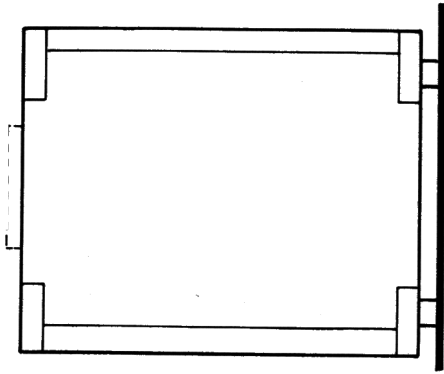
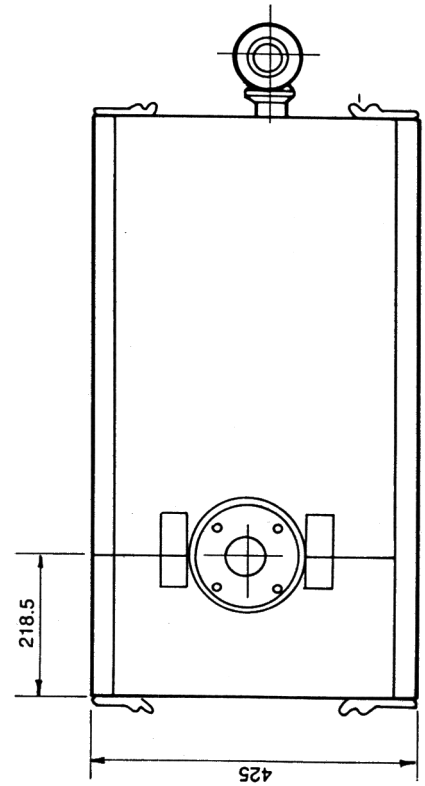
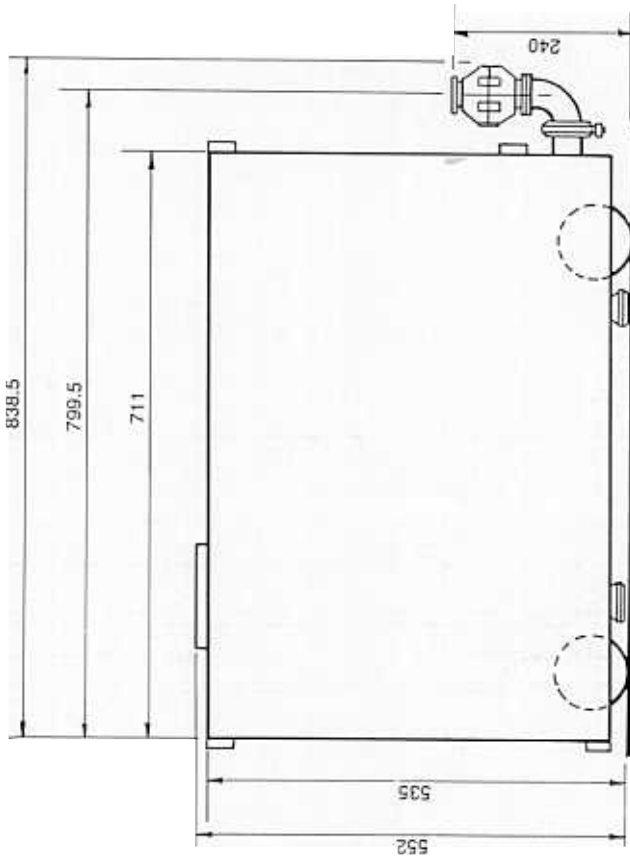

Figure 3 - CDP40i - Dimension Details

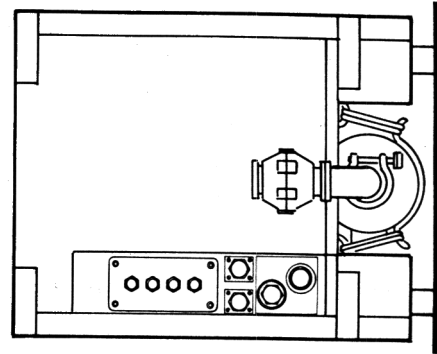
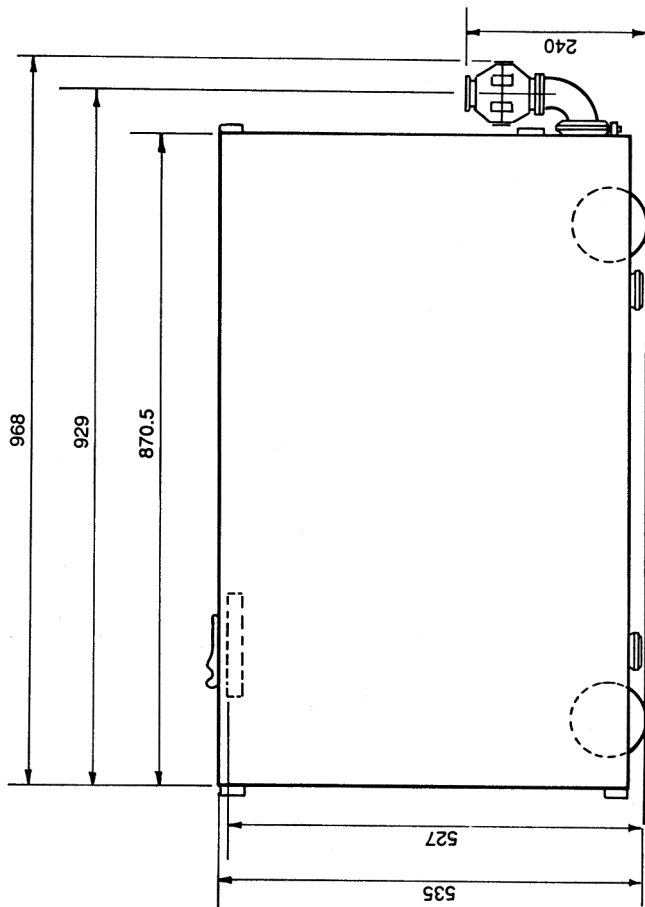
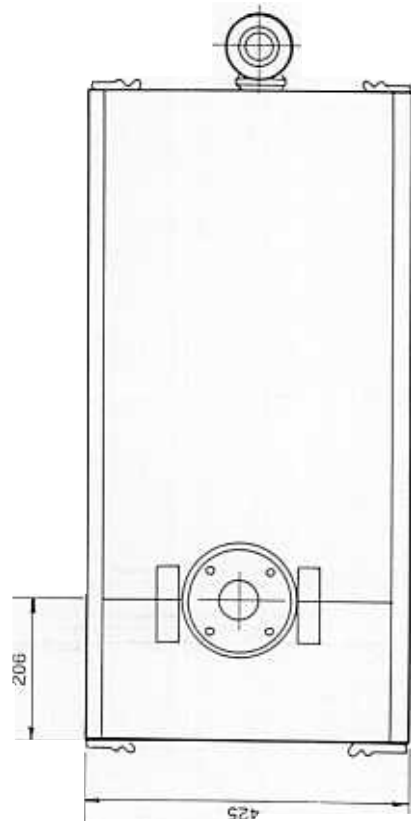

Figure 4 - CDP80i - Dimension Details



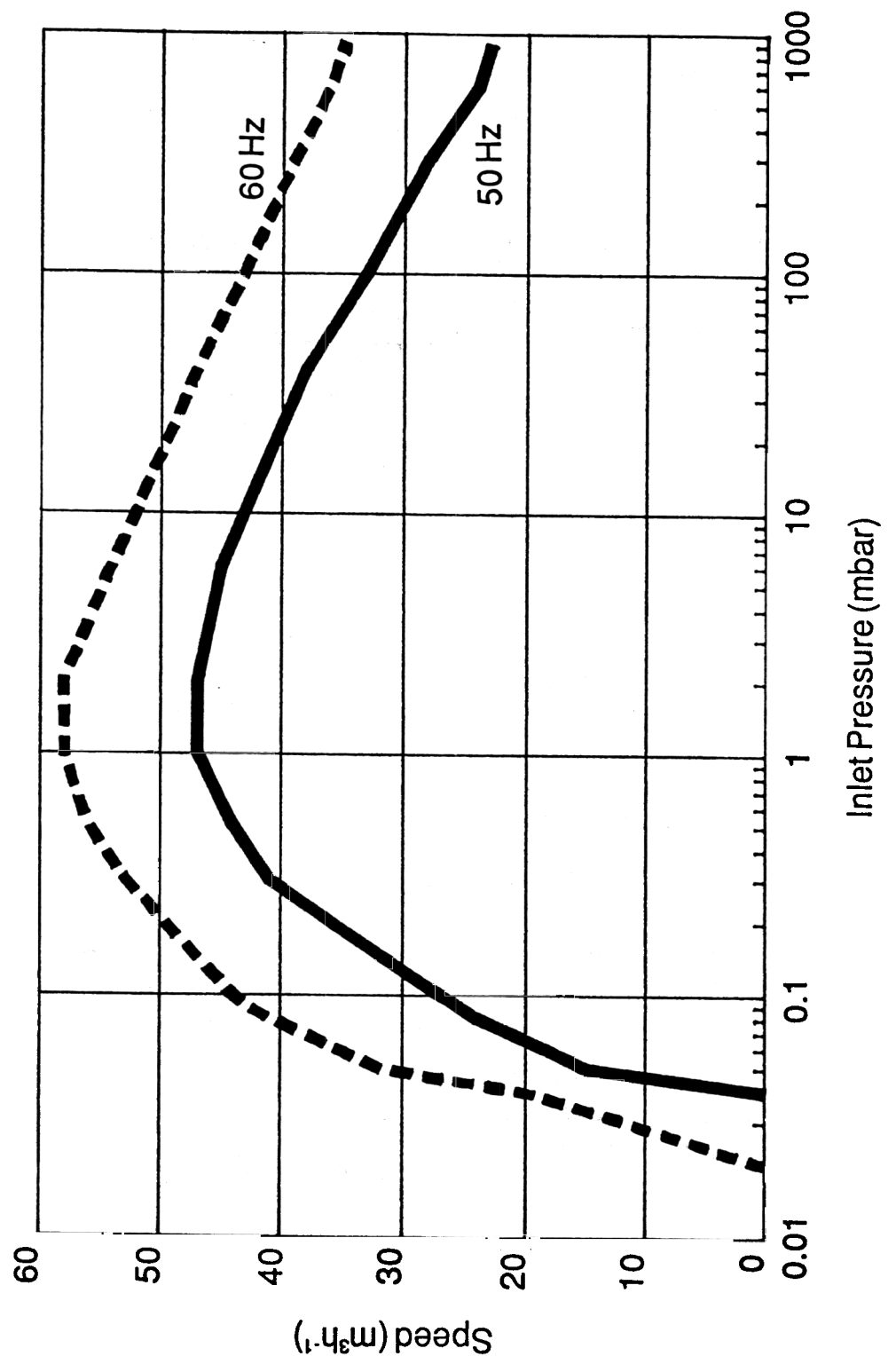

Figure 5 - CDP40i Performance

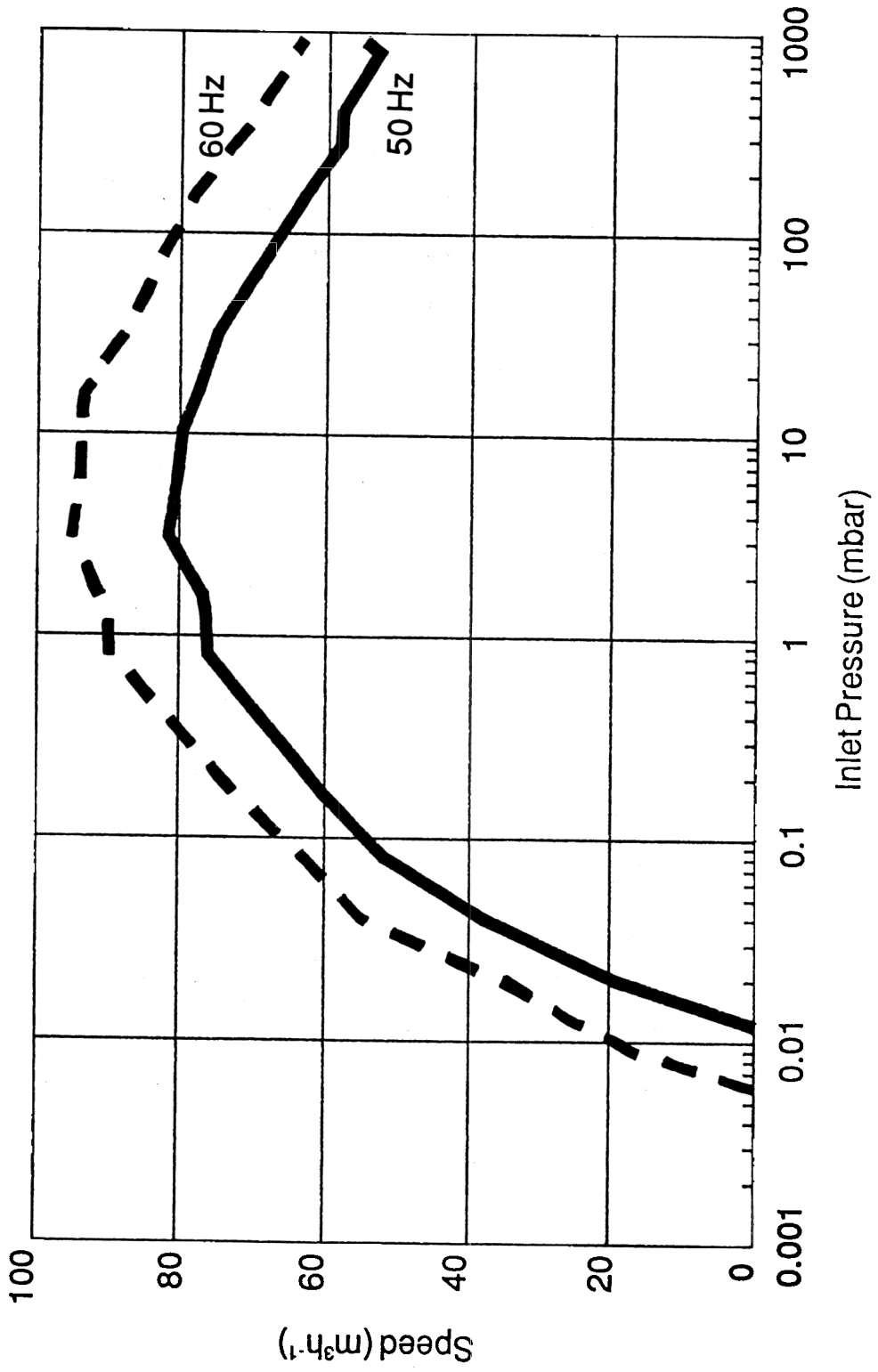

Figure 6 - CDP80i Performance

2.3 Services

	CDP40 i	CDP80 i
Cooling Water		
Maximum Consumption CDP40 i and CDP80 i at 20°C		
TCV Setting	Water Consumption	
0	300 lh ⁻¹	300 lh ⁻¹
1	300 lh ⁻¹	300 lh ⁻¹
2	300 lh ⁻¹	300 lh ⁻¹
2.5	130 lh ⁻¹	130 lh ⁻¹
3	60 lh ⁻¹	60 lh ⁻¹
3.5 (max)	50 lh ⁻¹	50 lh ⁻¹
Maximum Supply Pressure	100 psi	100 psi
Fittings Type	³ / ₈ inch Hansen couplings	
Pressure Differential across Pump		
TCV setting 0	15 psi	15 psi
TCV setting 3.5	20 psi	20 psi
Cooling Water Supply/Return		
Temperature Differential	18°C	22°C
Typical Heat removed from Pump	1.25 kW	1.75 kW
Nitrogen Supply Pressure	8 psi	8 psi
Typical Flow Rate	8 l.min ⁻¹	10 l.min ⁻¹
Fittings Type	6 mm compression	6 mm compression
Electrical Supply	See ordering codes	See ordering codes

2.4 Full Load Current Ratings

Supply Voltage → Frequency Model ↓	200V	208V	220V	230V	240V	380V	415V	460V
	50/60Hz	60Hz	50Hz	60Hz	50Hz	50Hz	50Hz	60Hz
	Full Load Current (A)							
CDP40i	9.2	8.8	8.4	8.0	7.7	4.9	4.5	4.0
CDP80i	16.0	15.4	14.5	13.9	13.4	8.4	7.7	7.0

The rating of the CDP80i motor is 4kW continuous and 5.7kW, S2, 15 minutes (refer to BS4999 part 101 and IEC34 part 101). The motor can be run with a load of 5.7kW for 15 minutes in any 2 hour period without damaging the motor. You may wish to select your motor protective devices accordingly.

2.5 Ordering Codes

	CDP40 i	CDP80 i
Number of Phases	3	3
Supply Voltage		
220/240V, 380/415V 50Hz	A527-42-935	A527-82-935
208/230/460V 60Hz	A527-42-995	A527-82-995
200V 50/60Hz	A527-42-934	A527-82-934

2.6 Cooling System

Type	Indirect water-to-coolant heat exchanger	
Coolant Type	H128-10-001	H128-10-001
Capacity	2.1 litres	2.1 litres
Water Control Valve		
Type	Thermostatic control valve (TCV)	
Manufacturer	Danfoss	Danfoss
Model	AVTA 15	AVTA 15
Maximum Working Temperature	130°C	130°C
Maximum Sensor Temperature	90°C	90°C

2.7 Lubrication System

Gear Box

Fluid Capacity (Timing Gear Box)	0.4 litres	0.4 litres
Grade of Oil	SAE 40	SAE 40
ISO Viscosity Grade	150	150
Recommended Oil Types		
Perfluoropolyether oils	Fomblin Y25 Krytox 1525	Fomblin Y25 Krytox 1525

Roller Bearings

Grease Type	Perfluoropolyether	Perfluoropolyether
Recommended Grease	Fomblin RT15 Krytox 240AD	Fomblin RT15 Krytox 240AD

Note: Please check with Edwards High Vacuum International before using alternative lubricants.

3 INSTALLATION AND COMMISSIONING

3.1 Safety

The installation of the CDP pump and its associated exhaust accessories must be performed by a competent technician. Because of the nature of the process products handled by the CDP range of pumps, you must obey the safety procedures listed below when carrying out installation work, especially when connecting into existing systems. Details of specific safety precautions are given at the appropriate point in the instructions.

Wear the appropriate safety clothing when handling contaminated components

Vent and purge the pumping system before starting any installation work

Check that all the required components are available and of the correct type before starting work

Ensure that the installation technician is familiar with the relevant safety procedures relating to the products handled by the pumping system

Disconnect the other components in the pumping system from the electrical supply so that they cannot be operated accidentally

Do not work un-supervised

Leak test the system after installation work is complete (minimum recommended requirement 10^{-5} mbar.l.s⁻¹ - helium)

Do not re-use 'O' rings and co-seals.

3.2 System Design Considerations

It is assumed that the CDP pump has been correctly selected for your application and that it is suitable for use with the product gases that you intend to pump. If you are in any doubt about the suitability of your pump for your specific application, please contact Edwards High Vacuum International for advice. The following points should be taken into consideration when designing your pumping system:

The CDP pump must be mounted on a firm, level platform

Vacuum pipework must be adequately supported to prevent loading of the vacuum joints

Both the exhaust silencer and exhaust check valve are designed for installation directly on to the pump and a 'fitting kit' is supplied with the pump to enable the direct fitting of these accessories. It is possible, however, to mount the accessories in alternative arrangements within an exhaust system providing a number of important rules are followed:

Always mount the exhaust check valve vertically with the flow arrow facing upwards in the direction of flow

CAUTION

Incorrect installation of the exhaust check valve can result in high exhaust system pressures and pump overload.

Always mount the exhaust silencer horizontally

Always locate the pump in its operating position before fitting the exhaust silencer; there is limited ground clearance underneath the Drystar unit, particularly when a silencer is fitted. Take great care, therefore, before moving the unit over surfaces which are rough and/or have a gradient

Include flexible bellows in the system (as shown in Figure 7) to reduce vibration and to preclude loading of the coupling joints

WARNING

The coupling joints of the exhaust silencer and the exhaust check valve must not be subjected to excessive loads or the integrity of the seal may be compromised.

WARNING

It is important to ensure that the exhaust line pressure does not exceed 6 psi. A facility should be installed to monitor the exhaust pressure and to automatically cut off the nitrogen purge in the event of the exhaust pressure reaching 6 psi.

WARNING

The CDP range of pumps can generate exhaust line pressures in the magnitude of 7 bar in the event of an exhaust blockage.

Figure 7 shows the right and wrong way of mounting the accessories. For information on specialist applications please contact Edwards High Vacuum International. For use with dry scrubbers, please refer to Edwards Application Note - Publication No. 12-A526-60-895 or contact Edwards High Vacuum International.

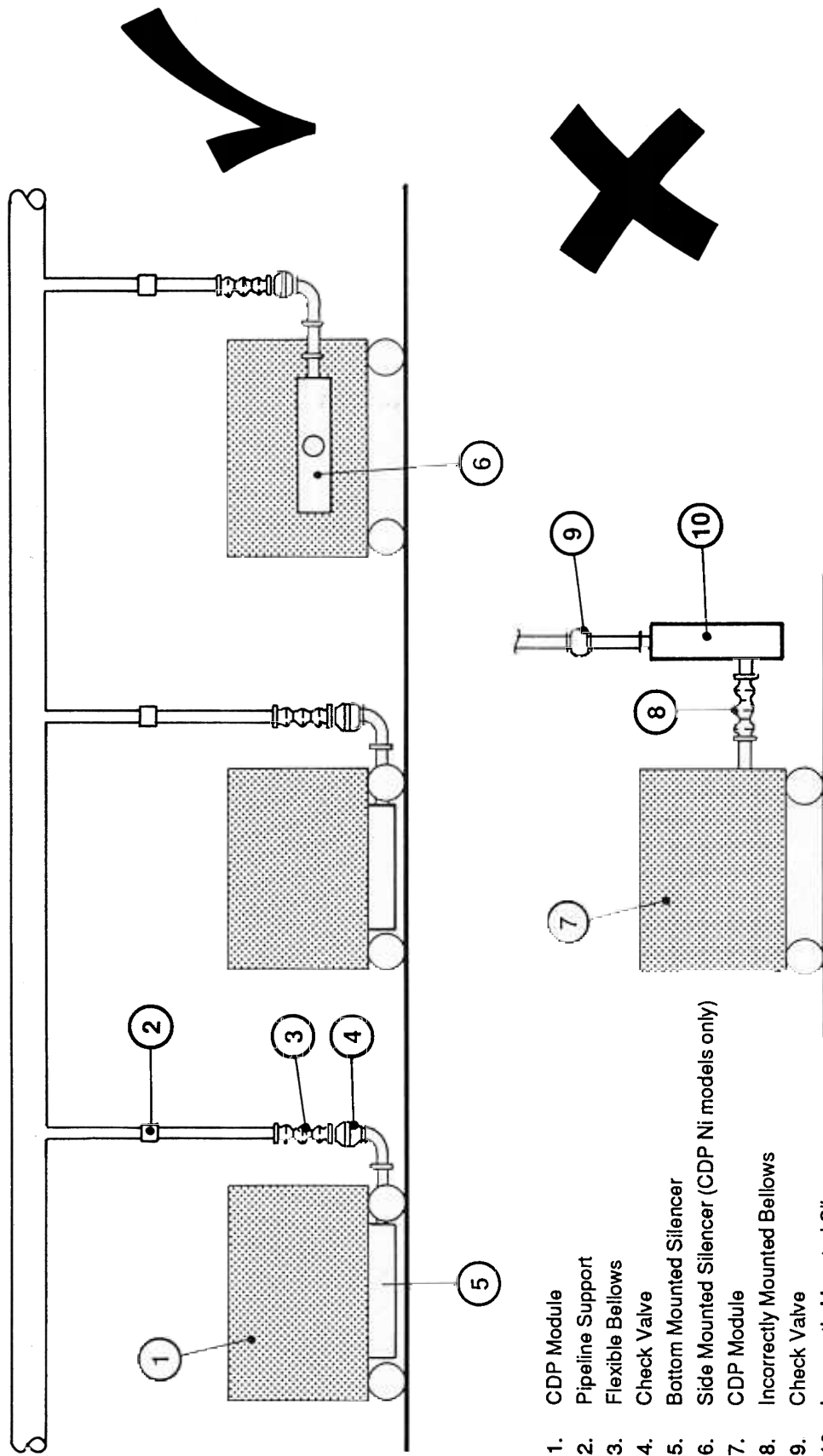

- 1. CDP Module
- 2. Pipeline Support
- 3. Flexible Bellows
- 4. Check Valve
- 5. Bottom Mounted Silencer
- 6. Side Mounted Silencer (CDP Ni models only)
- 7. CDP Module
- 8. Incorrectly Mounted Bellows
- 9. Check Valve
- 10. Incorrectly Mounted Silencer

Figure 7 - Mounting the Exhaust Line Accessories

WARNING

Do not operate the pump with the inlet open in such a way as to expose personnel to moving parts.

WARNING

On applications which involve corrosive gases or vapours, facilities must be available to isolate the pump outlet and inlet from atmospheric moisture and from the system when not in use.

WARNING

Before pumping noxious and pyrophoric gases, refer to Edwards Publication No. 03-A100-00-880, "Guidelines for eliminating the risk of explosion when pumping hazardous substances with primary vacuum pumps". Additional features must be fitted to the standard CDP to ensure safe pumping of such substances.

WARNING

Always consult Edwards High Vacuum International before pumping explosive gases or vapours, especially if they are in the German classification VDE-0171/2-61.

WARNING

If noxious gases or vapours are being pumped, then the discharge to the surrounding atmosphere must be prevented by piping the exhaust to a suitable treatment plant. In such cases, a catchpot must be used to prevent condensate in the effluent pipe draining back into the pump, either when the pump is in operation or when it is switched off.

An exhaust silencer and check valve must be fitted for all applications.

WARNING

CDP pumps contain PTFE, PFPE Grease and fluoroelastomer seals. In the unlikely event of a pump failure sufficiently severe to cause the internal temperature to rise to the extent to cause fluorine based polymers to decompose, utmost care must be taken to avoid exposure to the decomposition products. Ensure that the pump is correctly decontaminated after such an event.

3.3 Unpacking

On receipt, unpack the pump and its accessories in accordance with the following instructions and check visually for signs of damage. Any shortages or damage should be notified to Edwards High Vacuum International as soon as possible (see Health and Safety Form HS1 included at the end of this manual).

1. Position the palletted package containing the pump in a convenient position using a fork lift truck or pallet truck.
2. Open the cardboard box and remove the accessories and fitting kit.
3. Remove the packaging material from around the pump.
4. Using suitable lifting gear, remove the pump from its pallet using the lifting eye provided.

WARNING

Use appropriate lifting gear to move the pump from its pallet. Do not try to lift the pump by hand.

Weight of CDP40 i = 187 kg, weight of CDP80 i = 225 kg

3.4 Component Identification

The following list details the items that you will receive with your pump:

Qty	Item	Check(✓)
1	CDP i pump	<input type="checkbox"/>
1	Silencer (including supplementary instructions)	<input type="checkbox"/>
1	Check valve (including supplementary instructions)	<input type="checkbox"/>
1	Exhaust fitting kit	<input type="checkbox"/>
1	General fitting kit	<input type="checkbox"/>
1	Container of coolant	<input type="checkbox"/>
1	Installation and Operation Manual	<input type="checkbox"/>

When installing an accessory in accordance with the following instructions, use only the components supplied with the accessory and in the fitting kit supplied with the pump. Retain any packaging components removed during installation (such as sealing caps and blanking flanges) for future use.

3.5 Pre-installation Checks

WARNING

Before removing a pump from an existing system, purge the system with nitrogen for 15 minutes prior to handling.

If the pump is to be fitted in a new system, ensure that all preliminary pipework has been installed and that a suitable base for the pump has been prepared. Check that the following services and facilities are available for connection to the pump:

- Cooling water supply
- Cooling water return
- Electrical supply
- Nitrogen gas supply
- House exhaust system

3.6 Removing the Enclosure

The enclosure is held in position by 10 catches located on the front, rear and top panels (see Figure 8).

To unlock a catch, lift the raised (hinged) end and push back until the other end of the catch disengages; lift the catch free.

The enclosure should be removed as follows:

1. Disengage the 2 catches on one side of the front panel and the 2 catches on the same side of the rear panel. Remove the side panel.
2. Repeat step 1 for the other side panel.
3. Disengage the 2 catches either side of the pump inlet and remove the top panel.

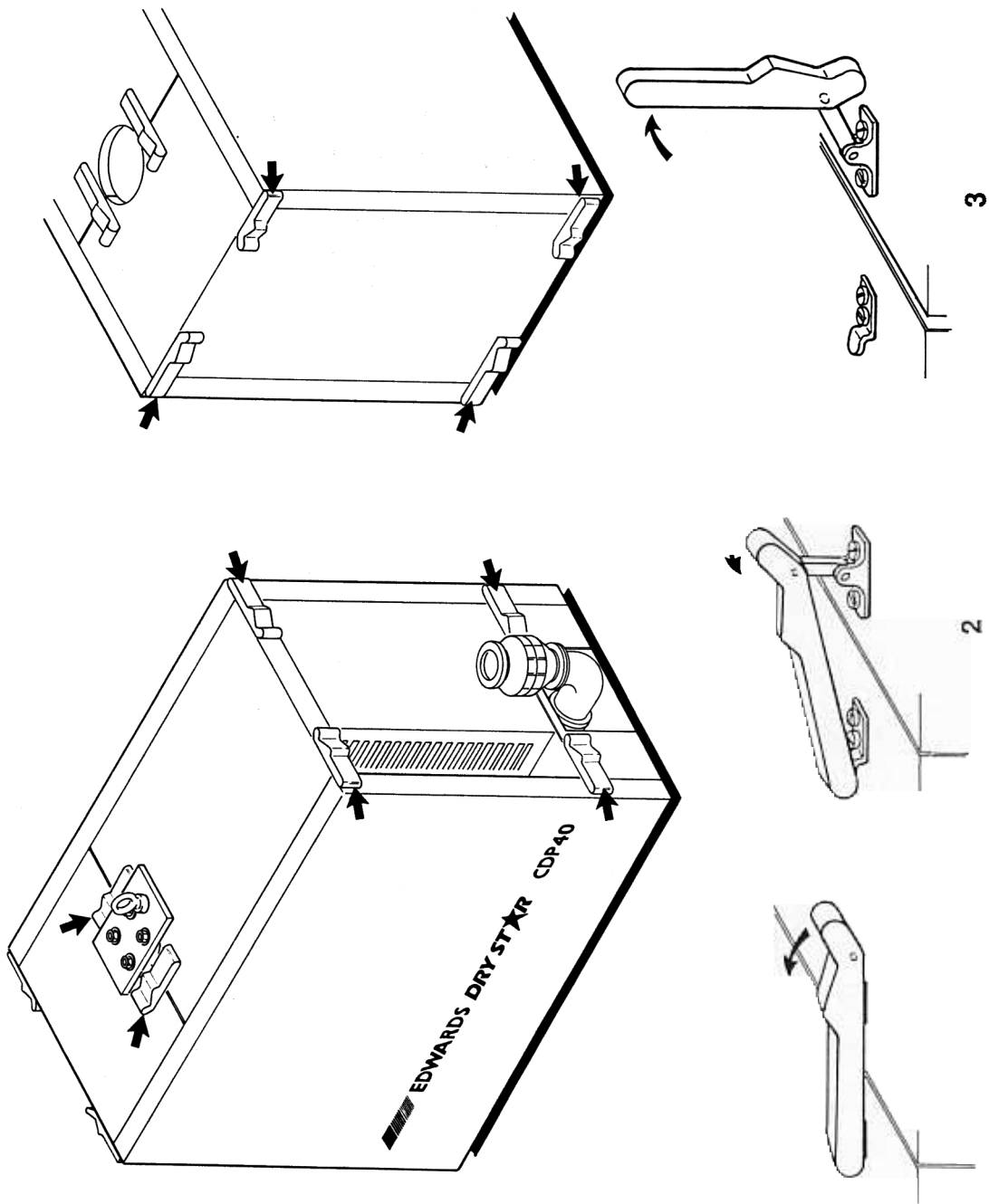

Figure 8 - Removing the Enclosure

3.7 Filling the Pump with Coolant

CAUTION

Failure to fill the CDP pump with the correct type and level of coolant could cause the pump to overheat and affect its performance.

The cooling water system and the location of its main components are shown in Figure 9. In addition to cooling the pump, the coolant acts as a corrosion inhibitor and anti-scaling agent. Fill the pump with coolant as follows:

WARNING

When checking the fluid level in the header tank, ensure that the pump electrical supply is switched off, that the pump has cooled down and that the cooling water supply is isolated.

1. Remove the cap from the CDP pump coolant container.
2. Pour in water until the 2.1 litre fill line on the container is reached; it is recommended that de-ionised water is used.
3. Replace the cap (firmly) on the container. Shake the container gently to mix fully the fluids.
4. Check that the coolant drain plug is securely fitted.
5. Unscrew the combined filler plug/level indicator from the pump header tank.
6. Unscrew and remove the $\frac{1}{8}$ inch BSP bleed plug from the top of the LV headplate using a flat bladed screwdriver.
7. Using a suitable clean funnel, slowly fill the pump with the coolant mixture, via the header tank, until fluid just appears at the top of the bleed hole.
8. Refit the $\frac{1}{8}$ inch BSP bleed plug to the threaded hole in the top of the LV headplate ensuring that the sealing 'O' ring is in place.
9. Slowly continue to fill the system until fluid can be seen in the bottom of the header tank.

1. Header Tank
2. Combined Filler Plug/
Level Indicator Location
3. 'O' Ring
4. Combined Filler Plug/
Level Indicator
5. Air Bleed Plug
6. 'O' Ring
7. Bleed Plug Location
8. Temperature Control
Valve
9. Cooling Water Out
10. Cooling Water In
11. Coolant Drain Plug
12. Thermal Snap Switch

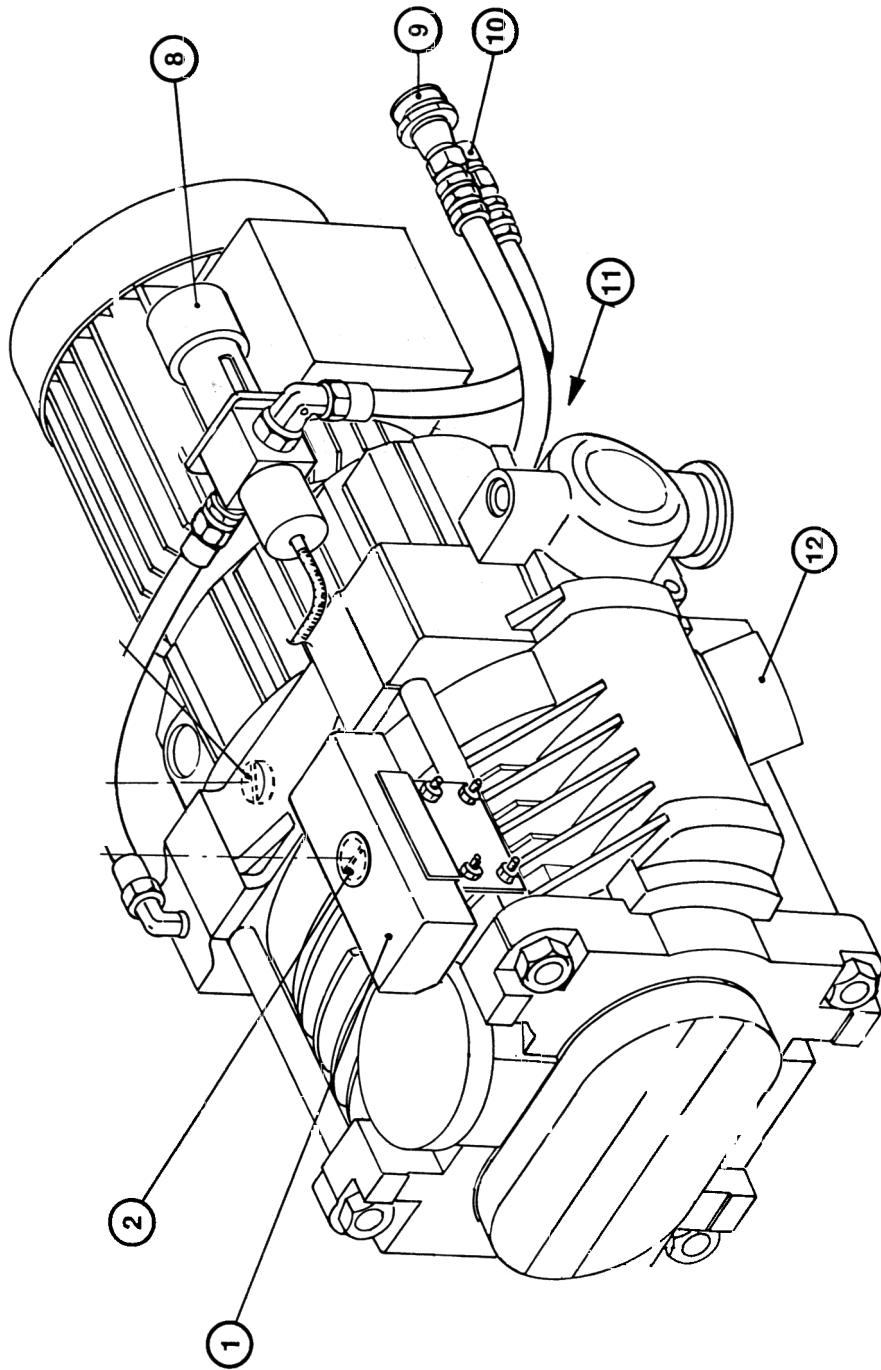

Figure 9 - Cooling System

10. Replace the combined filler plug/level indicator and then remove it to check the fluid level reached on the indicator shaft - the fluid level must not exceed the notch mark. Add more fluid if necessary.
11. Replace the combined filler plug/level indicator, ensuring that the 'O' ring is in position and correctly fitted.

3.8 Installing Optional Extras

The following optional extras should be fitted at this stage, before filling the pump with oil and siting it in its operating position.

Flap Valve, Part No. A519-20-021

Ei Controller, Part No. A380-41-000 for 200-208 V, CDP40 + EH250/EH500A

Ei Controller, Part No. A380-42-000 for 220-240 V, CDP40 + EH250/EH500A

Ei Controller, Part No. A380-43-000 for 380-415 V, CDP40 + EH250/EH500A

Ei Controller, Part No. A380-81-000 for 200-208 V, CDP80 + EH250/EH500A

Ei Controller, Part No. A380-82-000 for 220-240 V, CDP80 + EH250/EH500A

Ei Controller, Part No. A380-83-000 for 380-415 V, CDP80 + EH250/EH500A

3.9 Filling the Pump With Oil

WARNING

Most synthetic oils and greases can cause inflammation of the skin (dermatitis). Precautions must be taken to prevent direct skin contact with these substances. Use suitable protective gloves and clothing.

1. Check that the oil drain plug is securely fitted.
2. Unscrew the oil filler plug (see Figure 10).
3. Fill the reservoir with the recommended grade of oil to the MAX level mark on the oil level sight-glass.
4. Screw the oil filler plug back in and tighten to finger tight; using a spanner tighten an additional $\frac{1}{16}$ th of a turn, ensuring that the 'O' ring is in position and correctly fitted.

1. Oil Filler Plug
2. Oil Drain Plug
3. Oil Sight Glass

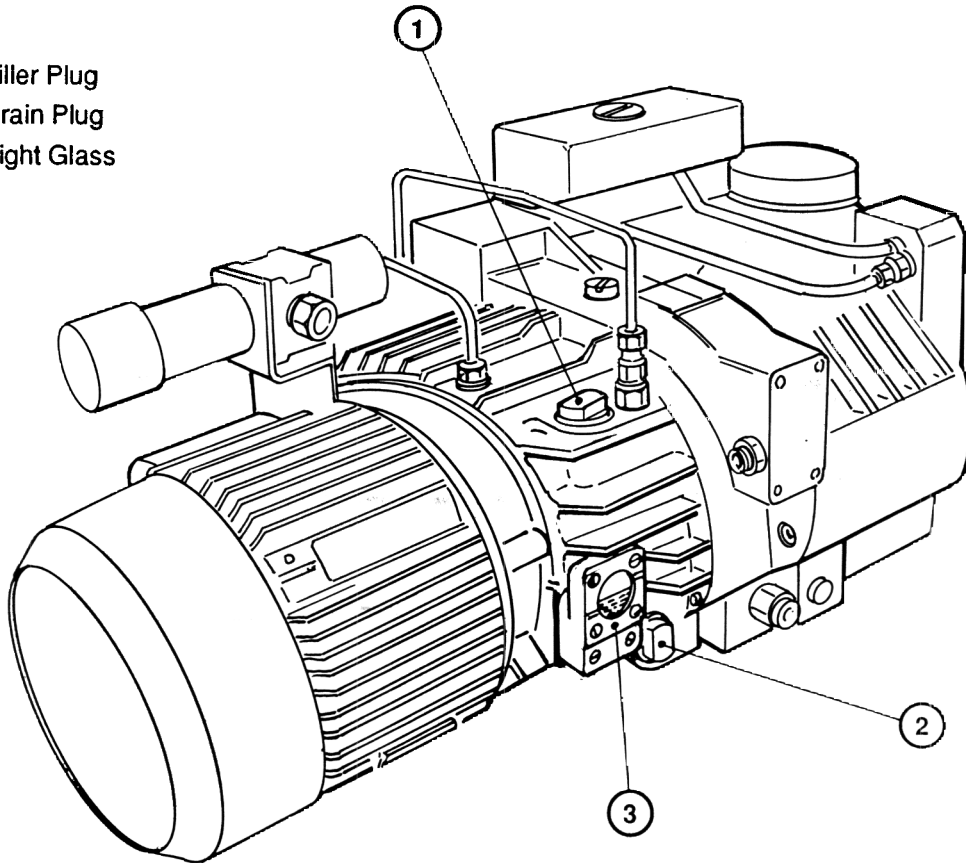

Figure 10 - Oil Filler Plug and Sight Glass Location

3.10 Siting the Pump

WARNING

Use appropriate lifting gear to move the pump from its palette. Do not try to lift the pump by hand.

Weight of CDP40 i = 187 kg, weight of CDP80 i = 225 kg

Before the exhaust accessories are fitted, the pump should be located in its final operating position. Move the pump into its operating position by wheeling it on its casters.

CAUTION

Before moving the pump, ensure that the positioning jacks are suitably retracted.

3.11 Installing the Exhaust Silencer

The following instructions assume that the exhaust silencer is to be installed in the recommended configuration.

If the exhaust silencer is being fitted to an existing system, purge the pump for 15 minutes before removing the existing silencer which can be removed by releasing the inlet and outlet flange clamps.

2. Refer to Figure 11 and select the correct pump configuration for your system.
3. Remove the protective cap from the long NW40 elbow outlet flange (supplied fitted) and check the mating surface to ensure that it is clean and free from defects; similarly, remove the protective cap and check the corresponding mating surface on the exhaust silencer inlet flange.

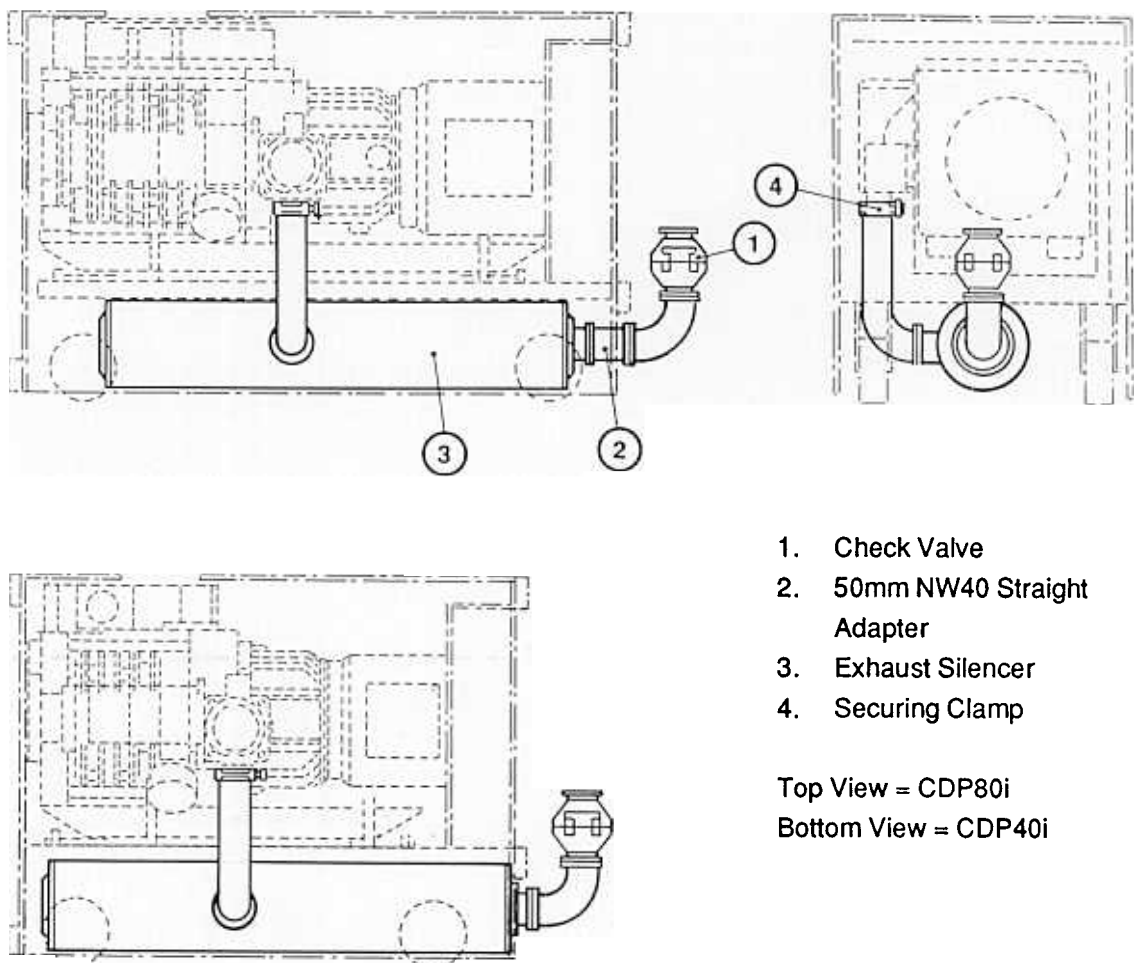

Figure 11 - Pump Exhaust Accessories

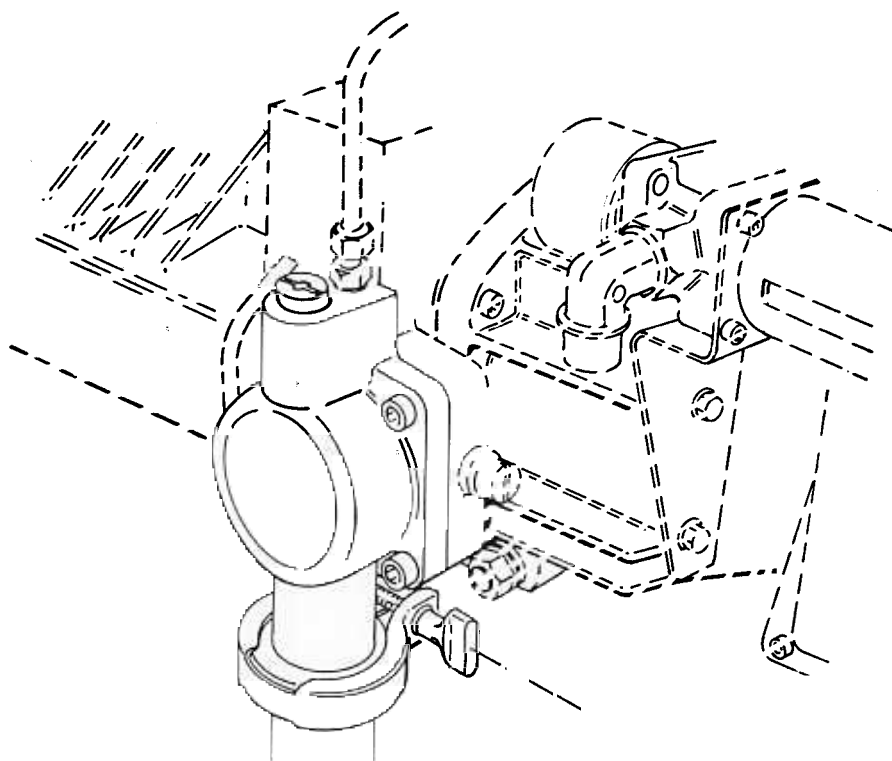

Figure 12 - Clamp Orientation

4. Check the clamp securing the NW40 elbow to the pump; ensure that : it is correctly orientated so that the seal remains functional under load induced by the silencer as its weight increases with particulate deposits; it is correctly positioned when the clamp bar is parallel with, and in its closest position to, the pump body as shown in Figure 12.

WARNING

Ensure that the NW40 clamp securing the NW40 elbow to the pump body is correctly orientated. Failure to correctly fit this clamp could adversely affect the integrity of the seal when the silencer has accumulated particulate deposits.

5. Where appropriate (i.e. on the CDP80 i), fit the 50 mm NW40 straight adaptor to the exhaust silencer outlet after removing the protective caps and checking that the mating surfaces are clean and free from damage; use the NW40 co-seal and NW40 clamp assembly provided in the exhaust fitting kit.

6. Position the exhaust silencer under the pump and fit two 'O' rings to each of the 3 hooks on the underside of the pump; fit the 'O' rings to the corresponding hooks on the exhaust silencer after checking that the silencer inlet is correctly aligned with the long NW40 elbow.
7. Remove the protective caps and secure the long NW40 elbow (from the pump outlet) to the exhaust silencer inlet using the NW40 co-seal and NW40 clamp assembly provided in the exhaust fitting kit (refer to Figure 11).

3.12 Installing the Exhaust Check Valve

The following instructions assume that the exhaust check valve is to be installed in the recommended configuration.

1. If the exhaust check valve is being fitted to an existing system, purge the pump for 15 minutes before removing the existing check valve which is removed by releasing the flange clamp.

Refer to Figure 11 and select the correct pump configuration for your system.

3. Remove the protective caps and check the mating surfaces of the NW40 short elbow (supplied with the pump fitting kit) to ensure that they are clean and free from defects; similarly, remove the protective caps and check the corresponding mating surfaces on the exhaust silencer outlet flange and the exhaust check valve inlet flange.
4. Fit the NW40 short elbow to the exhaust check valve using the NW40 co-seal and NW40 clamp assembly provided in the exhaust fitting kit; ensure that the flow direction arrow is facing upwards in the direction of flow.

CAUTION

Incorrect installation of the exhaust check valve can result in high exhaust system pressures and pump overload.

5. Fit the other end of the elbow to the exhaust silencer outlet (or adapter flange) using the NW40 co-seal and NW40 clamp assembly provided in the exhaust fitting kit.

3.13 Fitting a Booster Pump

If an EH series booster pump is to be fitted, it should be added at this stage. Full details of the fitting kits available are given in Section 6.3 and the procedure for fitting a pump is covered in the working instructions supplied with the appropriate fitting kit.

No special accessories are required, however, to connect the EH250 pump to the CDP40 i; the EH250 is fitted as follows:

On the CDP40 i

1. Remove the covers as detailed in Section 3.6
2. Remove the four M8 x 45 mm bolts securing the lifting bracket to the manifold blanking plate and inlet manifold; retain the nuts and bolts.
3. Remove the manifold blanking plate and retain.
4. Check the inlet manifold sealing face to ensure that it is free from scratches and blemishes.
5. Ensure that the sealing 'O' ring is correctly fitted.

On the EH250

6. Check the outlet manifold sealing face to ensure that it is free from scratches and blemishes.
7. Using suitable lifting equipment, position the booster pump outlet over the CDP40 i manifold inlet flange as shown in Figure 13.
8. Align the flanges and bolt together using the four M8 x 25 mm bolts supplied in the general fitting pack.
9. Refer to the EH250 pump's working instructions for details on connecting services to the booster pump and preparing it for operation.

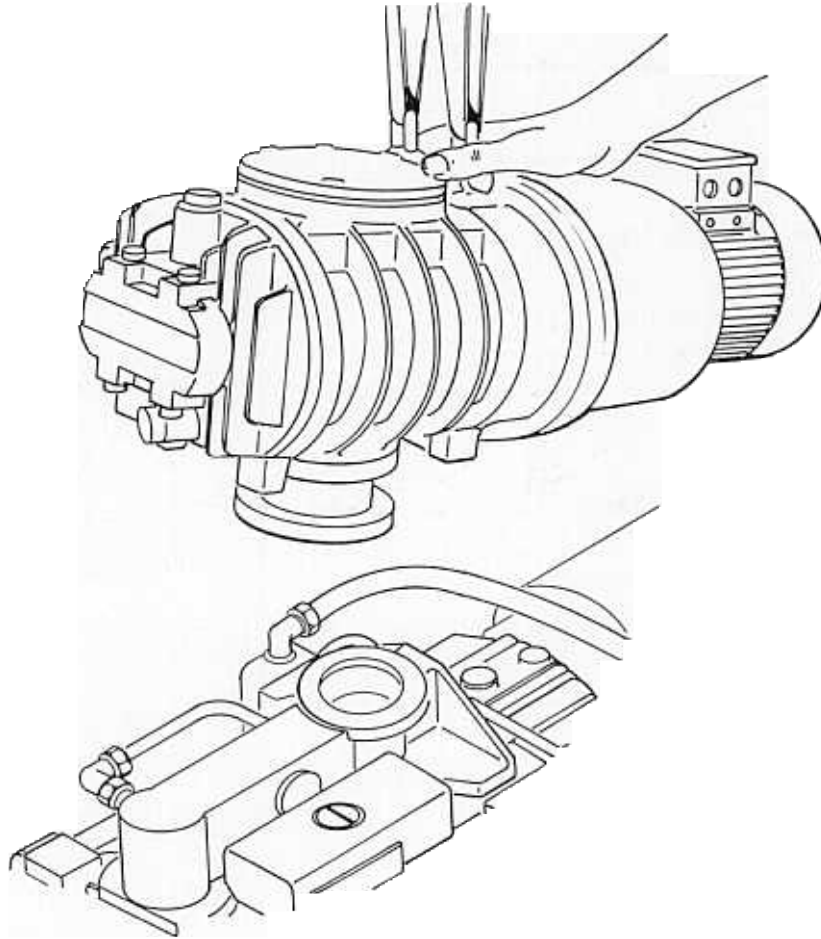

Figure 13 - Fitting the EH250 Booster Pump

3.14 Connecting the Cooling Water Supply

CAUTION

Ensure that the water supply is connected as shown on the pump services panel and that the flow and return connections are not reversed.

On pump combinations, the cooling water supply must be connected in parallel, not in series.

1. Locate and remove the male and female type quick-release connectors from the general fitting kit.

2. Fit these connectors to the cooling water service supply and return hose pipes (see Figure 14) using $\frac{3}{8}$ inch BSP male pipe fittings (to be supplied by the customer).
3. Remove the yellow dust caps from the connectors on the services panel.
4. Connect the water supply pipe to the WATER IN connector on the pump services panel.
5. Connect the water return pipe to the WATER OUT connector on the pump services panel.
6. Do not turn on the water supply yet.

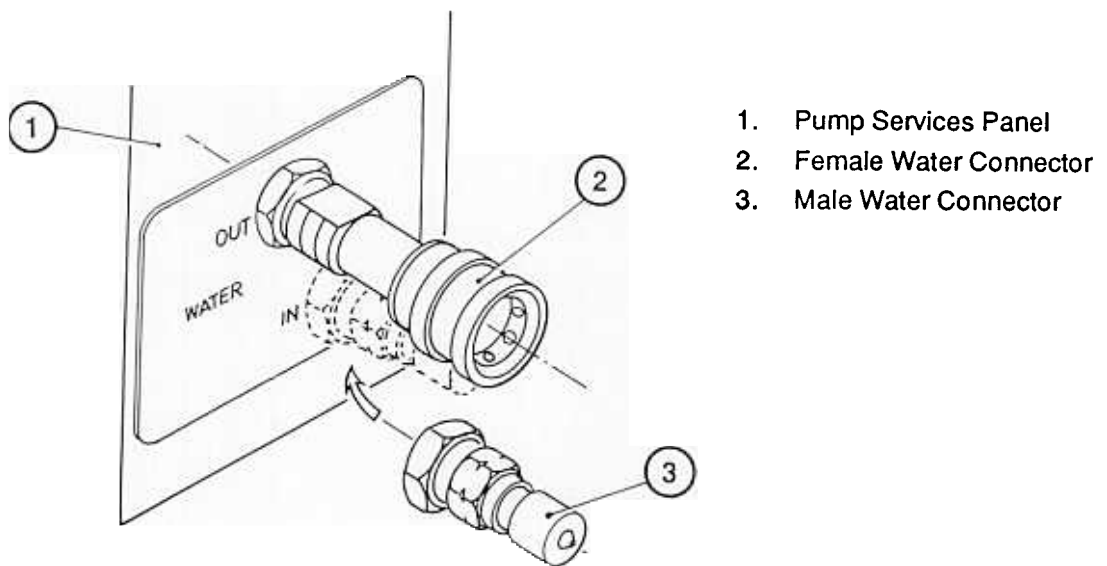

Figure 14 - Cooling Water Connections

Electrical Supply Connection

Connecting to a Contactor

WARNING

All electrical work must be carried out by a competent electrician.

The CDP i pumps are supplied with two armoured umbilical cables attached. Both the cables are 5 metres long and the larger diameter cable is used for connecting the pump motor to the electrical supply. The other cable is for the thermal snap switch and details for connecting this are contained in Section 3.15.3.

Before attempting to connect the pump motor, check that the electrical supply corresponds with the information printed on the pump data plate. Unless the Ei controller is being used (see Section 3.15.2) the electrical supply should be connected via a contactor incorporating an overload protection facility.

Ensure that the earth terminal of the pump motor is connected to a safety ground point at the a.c. supply source before the a.c. supply is connected. The steel braiding of the electrical cable must be earth bonded at a suitable point on a contactor starter unit.

3.15.2 Connecting the Ei Controller to the Electrical Supply

The Ei controller must be fitted to the electrical supply in accordance with the instructions contained in the Ei controller working instructions (see Publication No. 03-A380-41-880).

3.15.3 Connecting the Thermal Snap Switch

The thermal snap switch is attached to the cooling water jacket adjacent to the pump exhaust outlet (see Figure 9). A five metre length of cable, enclosed in an armoured umbilical, provides the electrical connection to the switch which has normally closed contacts rated at 240 V to 6.3 A inductive load (0.6 power factor) or 16 A resistive load (1.0 power factor). The switch may be used to provide pump protection in the following way:

WARNING

When using the snap switch to provide a warning alarm only, take suitable steps to ensure that warning is acted upon and can not be ignored.

1. By incorporating it into the electrical overload control loop of the motor starter. In the event of the pump sensor temperature rising above 71°C, the switch contacts will open and the starter will trip off.
2. By connecting it to other control instrumentation (such as the Ei controller) to provide audible and/or visual indication of pump overheat conditions.

The umbilical contains a three core cable; the green and yellow wire is the earth wire and should be connected to a suitable earthing point. The remaining two wires are connected to the switched contacts.

Checking Pump Rotation

The direction of pump motor rotation is checked as follows:

Remove the four bolts, nuts and washers securing the lifting bracket to the inlet manifold.

2. Leave the blanking plate in position on the inlet manifold and loosely secure with the four cap head bolts removed in step 1.

WARNING

When testing for correct motor shaft rotation, ensure that the blanking plate is loosely fitted to the inlet manifold. If the direction of rotation is incorrect, excessive pressures can be generated in the vacuum system.

3. While watching the inlet flange, apply power to the pump for one or two seconds and then switch off.
4. If the blanking plate lifts from the inlet flange when the pump is running, the direction of rotation is incorrect. Isolate the electrical supply and reverse any two of the phase wires in the contactor box.
5. Repeat the check to ensure that the direction of rotation is correct.
6. Refit the blanking plate to the inlet of the pump.

Leak Testing the Pump and its Accessories

Before the pump is connected to the system it is important that the pump and its associated exhaust line accessories are leak tested. The exhaust silencer and exhaust check valve are leak tested with helium to 10^{-5} mbar.l.s⁻¹ before dispatch. Further details on the procedures for leak testing are available from Edwards High Vacuum International.

It is important also to leak test the installation once the pump has been fitted (see Section 3.19) in order to ensure the integrity of the seals between the pump and the installation.

3.17 Connecting the Nitrogen Supply

The nitrogen gas connection to the pump is made via a single compression type fitting, the component parts of which are shown in Figure 15. It is recommended that the customer's supply is piped in a rigid metal tubing (such as stainless steel) with an outside diameter of 6 mm. The component parts (Figure 15, Items 1, 2 and 3) of the pipeline fittings are supplied in a bag attached to the nitrogen connector on the services panel.

1. Remove the blanking plug from the connector on the pump services panel and assemble items 1, 2 and 3 onto the supply pipe (4) as shown.
2. Screw the pipeline connection securely to the nitrogen inlet on the pump services panel.

CAUTION

The nitrogen supply must be fitted with a suitable regulator to maintain a constant pressure supply of 8 psig (0.55 bar gauge).

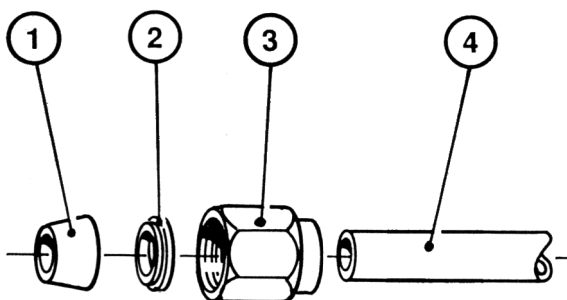

- | | |
|--------------------|--------------------------------|
| 1. Conical Ferrule | 3. Nut |
| 2. Backing Ferrule | 4. Pipe (supplied by customer) |

Figure 15 - Nitrogen Pipe Connector Components

WARNING

If nitrogen is supplied to the pump when it is not running, this will lead to a positive pressure being developed in the foreline. As it is unlikely that the foreline will be suitable for positive pressures, the use of an inlet valve or nitrogen supply solenoid valve, interlocked to the pump motor supply, must be used to prevent foreline pressurization

3. Check the routing of the pipe to ensure that it will not obstruct the enclosure when it is replaced.

3.18 Connecting to the Process System

The following instructions assume that a booster pump has not been fitted. If a booster pump is fitted, follow the instructions given in the booster pump manual for connecting the booster pump inlet to the process system.

The vacuum inlet flange at the top of the CDP40 i pump manifold has four 9 mm through holes, equi-spaced on an 80 mm PCD. It is suitable for connection to ISO40 vacuum flanges using cap-head bolts.

The vacuum inlet flange at the top of the CDP80 i pump manifold has four 9 mm through holes, equi-spaced on a 110 mm PCD. It is suitable for connection to ISO63 vacuum flanges using cap-head bolts.

For optimum pumping speed, the connecting pipeline should be kept to the minimum length possible and have a bore size not less than the pump inlet port dimensions. A flexible connection should be positioned in the pipeline from the system to the pump to reduce vibration and stress in the system pipework. On very dusty applications, the use of a low impedance inlet filter is recommended to minimise abrasion in the pump. The inlet flange of the CDP is connected as follows:

1. Remove the four M8 x 45 mm cap-head bolts and nuts and remove the inlet blanking plate.
2. Retain the nuts, bolts and washers for use at a later date
3. Connect the pump inlet flange to the process chamber using suitable piping and sealing mechanisms; secure using either the bolts provided in the general fitting pack or the M8 x 45 mm bolts removed in step 1 (depending on the fittings on the house system).

Leak Testing the Installation

Before the system is used it is important that the system is leak tested to prevent the leak of hazardous substances. The exhaust silencer and exhaust check valve are leak tested with helium to 10^{-5} mbar.l.s⁻¹ before dispatch. Further details on the procedures for leak testing are available from Edwards High Vacuum International.

WARNING

Always leak test the system after fitting components to the installation.

Replacing the Enclosure

If the pump is not required for service immediately, the enclosure should be refitted. If the pump is to be used immediately, do not refit the enclosure until the Pre-start Checks detailed in Section 4.2.1 have been carried out.

4 OPERATION

4.1 Introduction

CDP pumps are of rugged construction and are designed to provide long term, trouble free service provided the recommended operating and servicing procedures are adhered to.

Before dispatch, each pump is inspected and tested for performance. Many cases of suspected failure or poor pump performance are due to one of the following causes:

Leaks in the vacuum system

Faulty gauges

Contamination of gearbox oil

Contaminated ball bearing grease

Please check these points before calling for assistance.

4.2 Start-up Procedure

Before the pump is started it is necessary to carry out a number of preliminary checks to ensure that the pump is in a serviceable condition.

WARNING

Some parts of the pump can become hot during operation.

4.2.1 Pre-start Checks

1. Check the gearbox oil level using the sight-glass on the side of the pump (see Figure 10); ensure that the level is between the minimum and maximum marks. Top-up if necessary.
2. Check the coolant level in the pump header tank using the combined filler cap/level indicator.
3. Check that the pump is correctly installed (especially after initial installation and maintenance).

4.2.2 Start-up and Water Temperature Control Valve Setting

WARNING

Never operate the pump without the correct nitrogen supply connected

The thermostatic control valve (see Figure 9) maintains the pump at the pre-set operating temperature. It is adjustable between 0 (minimum) and 3.5 (maximum); These settings correspond to temperature settings of approximately 40°C and 65°C respectively.

- 1 Turn the adjuster knob fully clockwise to the minimum setting (0).
- 2 Turn on the water supply and allow a steady flow to establish.
- 3 Check all pipework and connections to ensure that there are no leaks.
- 4 Switch on the CDP pump (and booster if fitted).
- 5 Check that the exhaust pressure is less than 1150 mbar (absolute) during roughing.
- 6 Turn the adjuster knob anti-clockwise to the required setting

Note: During normal use a setting of 2 to 2.5 on the adjuster knob is recommended. When pumping condensable vapours, this should be increased to the maximum setting of 3.5.

- 7 The cooling water flow will be shut off until the pump reaches the pre-set operating temperature when the pump is running.
- 8 Allow the pump to run for approximately fifteen minutes to achieve normal operating temperature and to check the operation of the valve; then check all water hoses, vacuum pipes and the nitrogen system for possible leaks.
- 9 Fit the enclosure.

Note: The attainable vacuum improves with running time as the pump rotors expand and working clearances decrease. After about 15 minutes running (from cold) the optimum performance is reached.

4.2.3 Operational Checks

The following operational checks should be performed as part of the set-up procedure and 24 hours after start-up:

- 1 Check that the pump process inlet and outlet connections are secure.

Check that the pump is level and that the floor stabilizer jacks are in contact with the floor.

3. Check that the cooling water connections are secure and that there are no visible signs of leaks.
4. Check that all connections to the pump services panel are secure.
5. Check that the thermostatic control valve is set correctly.
6. Check that all electrical connections are secure.
7. Check that the enclosure is in place and secure.

Note: The operator is responsible for ensuring that the equipment is safe to operate.

4.2.4 Pumping Condensable Vapours

When pumping condensable vapours, the pump should be operated at a higher temperature so that condensation within the pump is prevented. The recommended operating temperature is 65°C, measured at the point shown in Figure 16. The temperature is adjusted by changing the water temperature control valve as detailed in Section 4.2.2.

CAUTION

In order to prevent seizure caused by differential contraction between the casing and the rotating mechanism of the pump, the setting of the thermostatic valve must not be lowered while the pump is hot.

Under certain operating conditions (dependent on pressure, process and temperature control valve setting) a temperature difference of 10 to 20 °C will exist between the thermal snap switch and the high temperature measuring point; in the event of a dangerous temperature rise, the snap switch will open, but the pump will only shut-down if the snap switch has been correctly wired into the contactor trip circuit (see Section 3.15.3).

1. Temperature Measurement Point
2. Thermal Snap Switch

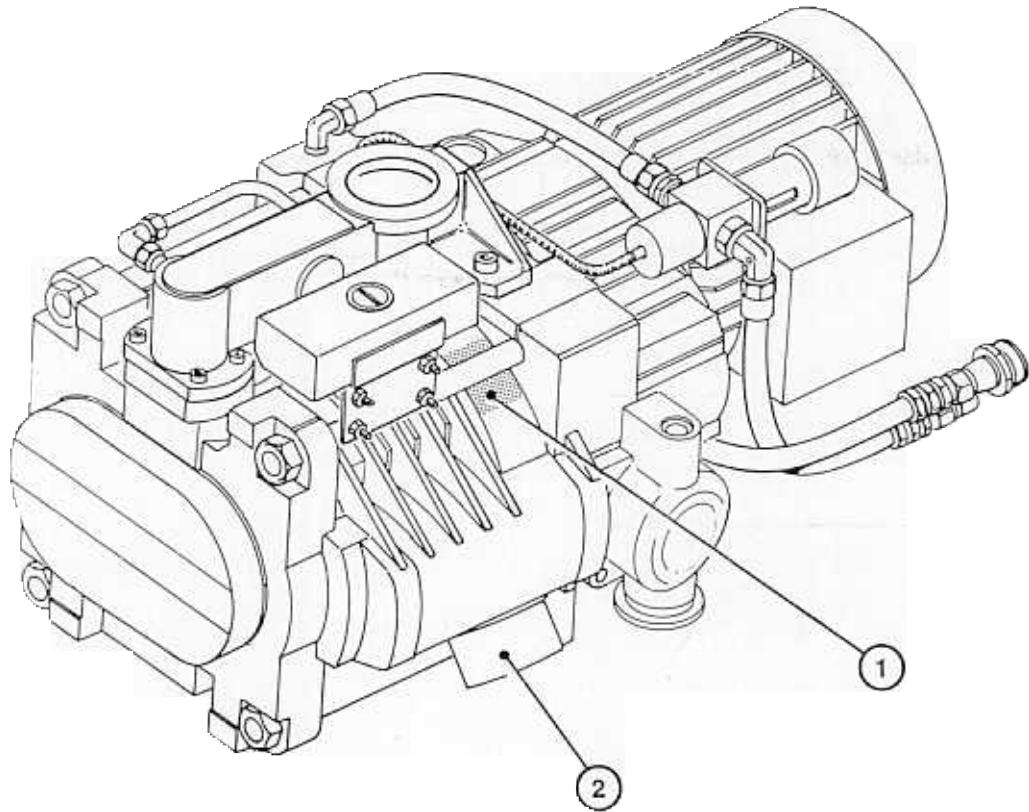

Figure 16 - Temperature Measurement Point

4.3 Pump Shut-down

WARNING

Before shut-down, purge the pump with nitrogen for 15 minutes.

1. Isolate the pump inlet and run for 15 minutes with the nitrogen supply switched on.
2. Switch off the CDP pump (and booster if fitted).
3. Turn off the cooling water supply.

5 MAINTENANCE

5.1 Introduction

The servicing intervals specified in the following paragraphs are provided as a guide for pump users. The periods should, however be adjusted in line with experience as time intervals are dependent on process conditions. When servicing the pump, it is advised that an Edwards service kit is used, which contains all of the necessary seals, lubricating grease and other components necessary to complete the service successfully. The part numbers of the service kits required for a complete (six-monthly) overhaul are as follows:

Routine maintenance kit - Part No. A526-40-820

Exhaust silencer servicing kit - Part No. A386-11-820

Exhaust check valve servicing kit - Part No. A440-03-820

5.2 Safety

The maintenance of the CDP pump and its associated exhaust accessories must be performed by a competent technician. Because of the nature of the process products handled by the CDP range of pumps, you must obey the safety procedures listed below when carrying out maintenance work. Details of specific safety precautions are given at the appropriate point in the instructions.

Wear the appropriate safety clothing when handling contaminated components

- Vent and purge the pumping system before starting any maintenance work

Check that all the required components are available and of the correct type before starting work

Ensure that the maintenance technician is familiar with the relevant safety procedures relating to the products handled by the pumping system

Disconnect the pump and other components in the pumping system from the electrical supply so that they can not be operated accidentally

Do not work un-supervised

Leak test the system after maintenance work is complete (minimum recommended requirement 10^{-5} mbar.l.s⁻¹ - helium) if such maintenance work has involved breaching the vacuum integrity of the system

Do not re-use 'O' rings and co-seals

Take care to protect sealing faces from damage.

WARNING

The pump and its accessories will remain hot for a period of time after use. Always allow sufficient time for the pump to cool to a safe handling temperature before starting maintenance work.

WARNING

Pump exhaust gases can be highly toxic. Take all necessary precautions when handling components that have (or could have) come into contact with them, including 'O' rings, gearbox oil and all exhaust accessories.

WARNING

Any items, such as 'O' rings and seals, removed during servicing, should not be re-used. Ensure that contaminated components are disposed of in a safe manner.

WARNING

If the electrical supply is disconnected for any reason during maintenance, the direction of pump rotation should be checked in accordance with Section 3.15.4.

5.3 Monthly Routine Maintenance

Check the pump gearbox oil level and top up if required; the level of fluid should be between the minimum and maximum marks when the pump is cold and at rest.

5.4 Three Monthly Routine Maintenance

1. Check the condition of the silencer in accordance with the procedures outlined in the exhaust silencer working instructions (see Publication No. A386-11-880).

Note: If the rate of sublimation of deposits is sufficient to exceed 7.5 kg before the next service interval, the service interval should be adjusted accordingly.

5.5 Six Monthly Routine Maintenance

General

1. Check the condition of the exhaust check valve in accordance with the procedures outlined in the check valve working instructions - see Publication No. A440-03-880.
2. Check all pipework for signs of damage or deterioration.
3. Check the coolant level using the combined filler plug/level indicator in the coolant header tank; top-up if required using the correct type of coolant (see Section 3.7).
4. Inspect gas lines for signs of corrosion; ensure that all gas line connections are secure.

Gearbox Oil Change

1. Remove the gearbox oil sump drain plug (see Figure 10) and drain the oil from the gearbox sump; ensure that the oil is collected in a suitable receptacle and is disposed of in a safe manner (subject to the process gases handled by the pump). Removing the oil filler plug will speed the draining process.
2. Discard the old 'O' rings on the oil filler and drain plugs and replace with new ones from the pump service kit.
3. Refit the gearbox sump drain plug, ensuring that the new 'O' ring is in position.
4. Fill the gearbox via the filler hole, with the correct grade and quantity of oil. Allow the oil to settle and check the level on the oil sight-glass.
5. Replace the oil filler cap, ensuring that the new 'O' ring is correctly positioned.

5.5.3 Rotor Bearing Re-lubrication

The rotor bearings (see Figure 17) should be cleaned, inspected and repacked with grease every six months. A tube of PFPE grease is supplied in the routine maintenance kit for this purpose. The procedure for re-lubricating the bearing is as follows:

1. Remove the six screws securing the bearing end cover to the high vacuum head plate.

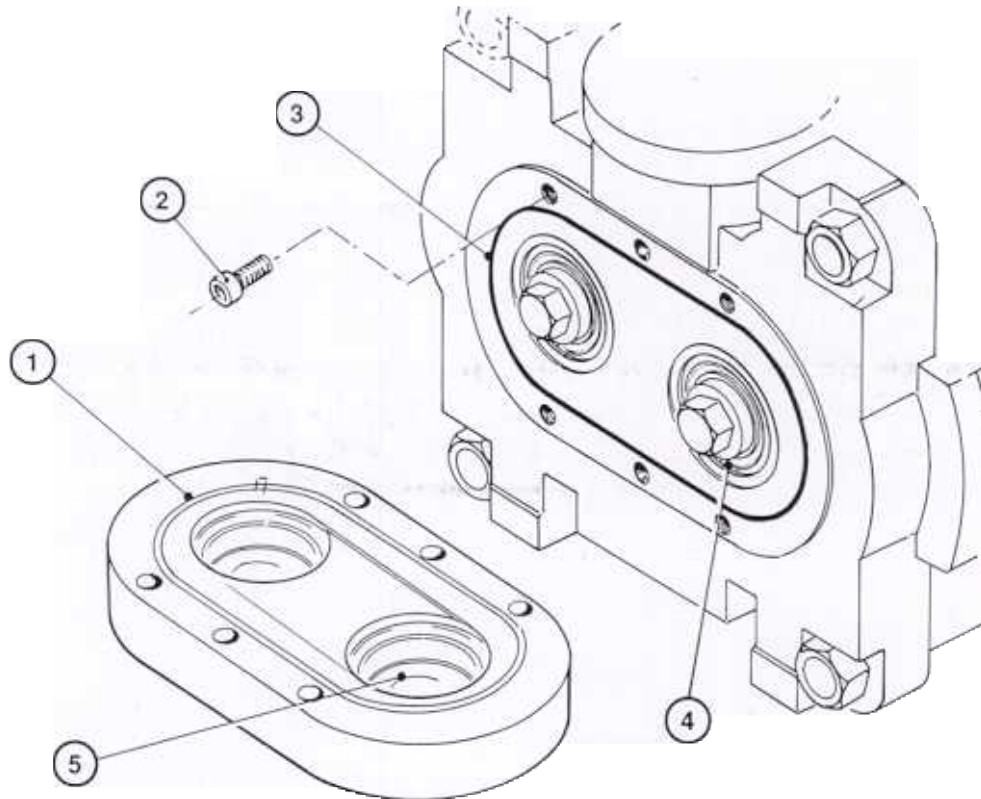

- | | |
|-----------------------------|-----------------|
| 1. Bearing End Cover | 4. Bearing |
| 2. End Cover Securing Screw | 5. Cover Cavity |
| 3. 'O' Ring | |

Figure 17 - Rotor Bearing Re-lubrication

- Lift away the end cover; remove the sealing 'O' ring and dispose of safely.

WARNING

Most synthetic oils and greases can cause inflammation of the skin (dermatitis).
Precautions must be taken to prevent direct skin contact with these substances. Use
suitable protective gloves and clothing.

- Using a plastic or wooden spatula, remove as much old grease as possible from the cover and bearings. Do not use your fingers for this operation.

4. Inspect the bearing for signs of wear. If the bearing does show signs of wear, the pump should be returned to Edwards High Vacuum International for repair.
5. If the bearing is in a satisfactory condition, force new PFPE grease (supplied in the service kit) into the bearing such that a smooth layer of grease covers the case and bearings. Do not over-pack the bearing or it will make the pump run hot.

CAUTION

Over-packing the bearings with grease may cause the bearings to run hot, leading to excessive wear and premature bearing failure.

6. Refit the end cover to the high vacuum headplate, ensuring that the new 'O' ring seal (lightly smeared with PFPE grease) is in position in its groove in the headplate.

Testing the Installation

After maintenance operations it is important that the system is leak tested to prevent the leak of hazardous substances. Further details on the procedures for leak testing are available from Edwards High Vacuum International.

WARNING

Always leak test the system after fitting components in the installation.

Maintenance Schedule

The following schedule details the procedures necessary to keep your CDP pump in working order. For details of the procedures required for each operation, please refer to the Sections listed in the last column of the table.

Operation	Interval			Refer to Section
	Monthly	3 Monthly	6 Monthly	
Check oil level	✘			5.3
Check coolant level			✘	5.5.1
Inspect gas lines			✘	5.5.1
Service exhaust silencer		✘		5.4
Service exhaust check valve			✘	5.5.1
Check all pipework			✘	5.5.1
Change gearbox oil			✘	5.5.2
Re-lubricate rotor bearing			✘	5.5.3
Leak test the installation			✘	5.6

5.8 Overhaul

The procedures for carrying out overhaul are beyond the scope of this manual. Such work should only be carried out by Edwards or its appointed service centres.

6 SPARES AND ACCESSORIES

Introduction

All Edwards products are readily available from Edwards High Vacuum International companies in Brazil, Canada, Italy, Japan, U.S.A, Germany and a worldwide network of distributors. The majority of distributors employ Service Engineers who have undergone comprehensive training at Edwards High Vacuum International, U.K.

How to Order Spares

Spare parts should be ordered through your nearest Edwards group company, distributor or service centre. Service centres are listed at the end of this publication.

When ordering spare parts for your CDP pump, please quote the following information:

- Pump model number
- Serial number
- Code number of part required
- Description (in words) of the part required
- The quantity required

List of Accessories

The following accessories are available for the CDP i model pumps:

Item	Order Code
Fitting kit for EH250 booster pump to CDP80 i	A504-55-000
Fitting kit for EH500A booster pump to CDP40 i	A504-56-000
Fitting kit for EH500A booster pump to CDP80 i	A504-54-000
Flap valve	A504-51-000

Item	Order Code
Ei Controllers	
DP40 + EH250/500A, 200 - 208 V	A380-41-000
DP40 + EH250/500A, 220 - 240 V	A380-42-000
DP40 + EH250/500A, 380 - 415 V	A380-43-000
DP80 + EH250/500A, 200 - 208 V	A380-81-000
DP80 + EH250/500A, 220 - 240 V	A380-82-000
DP80 + EH250/500A, 380 - 415 V	A380-83-000
Exhaust Silencer - CDP40/80	A386-11-000
Check Valve - CDP40/80	A440-03-000
CDP40i Nitrogen Purge Kit	A504-45-000
CDP80i Nitrogen Purge Kit	A504-85-000

7 HEALTH AND SAFETY ASPECTS - LUBRICANTS

7.1 Inhalation

Class A - Lubricants do not normally give rise to harmful concentrations of vapour except where high temperatures and open systems are involved.

Class B - Edwards recommended products in Class B are particularly inert and unlikely to give rise to harmful vapours when used in the applications for which they are recommended.

Care should, however, be taken to avoid inhalation of vapours or mists arising from undue heating or excessive mist generation. In the case of fluorinated compounds (e.g. Fomblin, Halocarbon) avoid contact with excessive heat (300°C) e.g. lighted cigarettes, heater elements, etc.

7.2 Fire Hazards/Storage and Spillage

These products do not require any special fire precautions but it is recommended practice to store them away from heat. When heat is required to facilitate handling of the product, this should be kept to a minimum.

If the pump operates in close proximity to possible sources of ignition, or where oxygen may form a large portion of the pumped load, then suitable fire resistant pump oils (such as Fomblin) should be used.

The pumping of significant amounts of flammable gases and vapours can also present a safety hazard since explosive mixtures can exist in pump component housings, mist filters and effluent pipes. This hazard can sometimes be controlled by diluting the effluent with nitrogen gas ballast or nitrogen flush and the fire risk reduced by the use of non-flammable pump oil. Control methods, however, depend on particular circumstances.

Fluid spillage should be absorbed with sand, earth or mineral absorbent and disposed of in accordance with the Disposal of Poisonous Wastes Act and Control of Pollution Act 1974.

In the event of large spillages, steps should be taken to prevent pollution of drainage systems, rivers or waterways, or infringement of the above acts.

Return of Edwards Equipment - Procedure (Form HS1)

Introduction

Before you return your equipment you must warn your supplier if the substances you used (and produced) in the equipment can be dangerous. You must do this to comply with health and safety at work laws.

You must complete the Declaration (HS2) on the next page and send it to your supplier before you dispatch the equipment. If you do not, your supplier will assume that the equipment is dangerous and he will refuse to accept it. If the Declaration is not completed correctly, there may be a delay in processing your equipment.

Guidelines

Take note of the following guidelines:

- Your equipment is 'uncontaminated' if it has not been used or if it has only been used with substances that are not dangerous. Your equipment is 'contaminated' if it has been used with any dangerous substances.
- If your equipment has been used with radioactive substances, you must decontaminate it before you return it to your supplier. You must send independent proof of decontamination (for example a certificate of analysis) to your supplier with the Declaration (HS2). Phone your supplier for advice.
- We recommend that contaminated equipment is transported in vehicles where the driver does not share the same air space as the equipment.

PROCEDURE

Use the following procedure:

1. Contact your supplier and obtain a Return Authorisation Number for your equipment.
2. Turn to the next page(s), photocopy and then complete the Declaration (HS2).
3. Remove all traces of dangerous gases: pass an inert gas through the equipment and any accessories which will be returned to your supplier. Drain all fluids and lubricants from the equipment and its accessories.
4. Disconnect all accessories from the equipment. Safely dispose of the filter elements from any oil mist filters.
5. Seal up all of the equipment's inlets and outlets (including those where accessories were attached). You may seal the inlets and outlets with blanking flanges or heavy gauge PVC tape.
6. Seal contaminated equipment in a thick polythene bag. If you do not have a polythene bag large enough to contain the equipment, you can use a thick polythene sheet.
7. If your equipment is a large pump (or any other large piece of equipment), strap the equipment and its accessories to a wooden pallet. Preferably, the pallet should be no larger than 510mm x 915mm (20" x 35"); contact your supplier if you cannot meet this requirement.
8. If your equipment is too small to be strapped to a pallet, pack it in a suitable strong box.
9. If the equipment is contaminated, label the pallet (or box) in accordance with laws covering the transport of dangerous substances.
10. Fax or post a copy of the Declaration (HS2) to your supplier. The Declaration must arrive before the equipment.
11. Give a copy of the Declaration to the carrier. You must tell the carrier if the equipment is contaminated.
12. Seal the original Declaration in a suitable envelope; attach the envelope securely to the outside of the equipment package. **WRITE YOUR RETURN AUTHORISATION NUMBER CLEARLY ON THE OUTSIDE OF THE ENVELOPE OR ON THE OUTSIDE OF THE EQUIPMENT PACKAGE.**

Return of Edwards Equipment - Declaration (Form HS2)

Return Authorisation Number: _____

You must:

- Know about all of the substances which have been used and produced in the equipment before you complete this Declaration
- Read the Procedure (HS1) on the previous page before you attempt to complete this Declaration
- Contact your supplier to obtain a Return Authorisation Number and to obtain advice if you have any questions
- Send this form to your supplier before you return your equipment

SECTION 1 : EQUIPMENT

Equipment model _____

Serial Number _____

Has the equipment been used, tested or operated?

yes Go to Section 2 no Go to Section 4

FOR SEMICONDUCTOR APPLICATIONS ONLY :

Tool Reference Number _____

Process _____

Failure Date _____

Serial Number of Replacement Pump _____

SECTION 2 : SUBSTANCES IN CONTACT WITH THE EQUIPMENT

Are any of the substances used or produced in the equipment

- Radioactive yes no
- Biologically active yes no
- Dangerous to human health and safety? yes no

If you have answered 'no' to all of these questions, go to Section 4.

Your supplier will not accept delivery of any equipment that is contaminated with radioactive substances, unless you:

- Decontaminate the equipment
- Provide proof of decontamination

YOU MUST CONTACT YOUR SUPPLIER FOR ADVICE BEFORE YOU RETURN SUCH EQUIPMENT

SECTION 3 : LIST OF SUBSTANCES IN CONTACT WITH THE EQUIPMENT

Substance name	Chemical symbol	Precautions required (for example, use protective gloves, etc.)	Action required after spillage or human contact
1			
2			
3			
4			
5			
6			

SECTION 4 : RETURN INFORMATION

Reason for return and symptoms of malfunction: _____

If you have a warranty claim:

- who did you buy the equipment from ? _____
- give the supplier's invoice number _____

SECTION 5 : DECLARATION

Print your name: _____ Print your job title: _____

Print your organisation: _____

Print your address: _____

Telephone number: _____ Date of equipment delivery: _____

I have made reasonable enquiry and I have supplied accurate information in this Declaration. I have not withheld any information. I have followed the Return of Edwards Equipment Procedure (HS1) on the previous page.

Signed: _____ Date: _____

Edwards International

EUROPE

UNITED KINGDOM

Edwards High Vacuum International
Manor Royal
Crawley
West Sussex RH10 2LW
Tel: (01293) 528844
Fax: (01293) 533453

BELGIUM

Edwards
Bergensesteenweg 709
B1600 Sint-Pieters-Leeuw
Tel: 2 360 3671
Fax: 2 360 3591

FRANCE

Edwards SA
125 Avenue Louis Roche
92238 Gennevilliers, Cedex
Tel: (1) 4798 2401
Fax: (1) 4798 4454

GERMANY

Edwards Hochvakuum GmbH
Postfach 1409
D35004 Marburg
Tel: 6420 82410
Fax: 6420 82411

ITALY

Edwards Alto Vuoto SpA
Via Carpaccio 35
20090 Trezzano Sul Naviglio
Milano
Tel: 2 4840 2258
Fax: 2 4840 1638

SWITZERLAND

Edwards (ECH)
Postfach
CH-4104 Oberwil-Basel
Tel: 61 401 4344
Fax: 61 401 4352

AMERICAS

USA

Edwards High Vacuum International
One Edwards Park
301 Ballardvale Street
Wilmington, MA 01887
Tel: 508 658 5410
Fax: 508 658 7969

Edwards High Vacuum International
Sierra Technology Center
Building 'A' Suite 120
3100 Alvin Devane Boulevard
Austin, TX 78741
Tel: 512 389 3883
Fax: 512 389 3890

Edwards High Vacuum International
550 Sycamore Drive
Milpitas, CA 95035
Tel: 408 946 4707
Fax: 408 946 8510

CANADA

Edwards High Vacuum
3375 North Service Road
Units B2/B3
Burlington
Ontario, L7N 3G2
Tel: 905 336 9119
Fax: 905 845 4924

BRAZIL

Edwards Alto Vácuo
Rua Bernardo Wrona, 222
Bairro do Limão
02710 - São Paulo - SP
Tel: 11 858 0377
Fax: 11 265 2766

PACIFIC

JAPAN

Nippon Edwards KK
12-15 Shimomaruko 2-chome
Ohta-Ku
Tokyo 146
Tel: 3 3756 4090
Fax: 3 3756 4509

Nippon Edwards KK
431-1 Yokata Gocha-Ku
Mikumi-Cho
Himeji
Hyogo 671-01
Tel: 792 523190
Fax: 792 523191

Nippon Edwards KK
Tajiri 1765-5 Kunitomi-Cho
Higashi Morokata-gun
Miyazaki
Tel: 985 758901
Fax: 985 754643

HONG KONG

Edwards High Vacuum (Pacific)
1308 Tower II
World Trade Square
123 Hoi Bun Road
Kwun Tong, Kowloon
Hong Kong
Tel: 796 9111
Fax: 796 9095

REPUBLIC OF KOREA

Songwon Edwards Ltd
Sun In Building
738-41 Panpo-Dong
Sochu Gu, Seoul
Tel: 2 515 1811
Fax: 2 515 1818

TAIWAN

Zimmerman Scientific Co Ltd
Golden Dragon Building
8FL No. 127
Fu-Shin South Road
Section 1, Taipei
Tel: 2 752 7075
Fax: 2 771 9415



Edwards High Vacuum International is part of BOC Limited
The stripe symbol is a trade mark of The BOC Group